



POWERING INNOVATION THAT DRIVES HUMAN ADVANCEMENT

© 2025 ANSYS, Inc. or its affiliated companies
Unauthorized use, distribution, or duplication is prohibited.

Getting Started with Q3D Extractor®: A 2D Grounded Coplanar Waveguide Model



ANSYS, Inc.
Southpointe
2600 Ansys Drive
Canonsburg, PA 15317
ansysinfo@ansys.com
<https://www.ansys.com>
(T) 724-746-3304
(F) 724-514-9494

Release 2025 R1
January 2025

ANSYS, Inc. and
ANSYS Europe,
Ltd. are UL
registered ISO
9001:2015
companies.

Copyright and Trademark Information

© 1986-2025 ANSYS, Inc. Unauthorized use, distribution or duplication is prohibited.

ANSYS, Ansys Workbench, AUTODYN, CFX, FLUENT and any and all ANSYS, Inc. brand, product, service and feature names, logos and slogans are registered trademarks or trademarks of ANSYS, Inc. or its subsidiaries located in the United States or other countries. ICFM CFD is a trademark used by ANSYS, Inc. under license. All other brand, product, service and feature names or trademarks are the property of their respective owners. FLEXIm and FLEXnet are trademarks of Flexera Software LLC.

Disclaimer Notice

THIS ANSYS SOFTWARE PRODUCT AND PROGRAM DOCUMENTATION INCLUDE TRADE SECRETS AND ARE CONFIDENTIAL AND PROPRIETARY PRODUCTS OF ANSYS, INC., ITS SUBSIDIARIES, OR LICENSORS. The software products and documentation are furnished by ANSYS, Inc., its subsidiaries, or affiliates under a software license agreement that contains provisions concerning non-disclosure, copying, length and nature of use, compliance with exporting laws, warranties, disclaimers, limitations of liability, and remedies, and other provisions. The software products and documentation may be used, disclosed, transferred, or copied only in accordance with the terms and conditions of that software license agreement.

ANSYS, Inc. and ANSYS Europe, Ltd. are UL registered ISO 9001: 2015 companies.

U.S. Government Rights

For U.S. Government users, except as specifically granted by the ANSYS, Inc. software license agreement, the use, duplication, or disclosure by the United States Government is subject to restrictions stated in the ANSYS, Inc. software license agreement and FAR 12.212 (for non-DOD licenses).

Third-Party Software

See the legal information in the product help files for the complete Legal Notice for Ansys proprietary software and third-party software. If you are unable to access the Legal Notice, please contact ANSYS, Inc.

Conventions Used in this Guide

Please take a moment to review how instructions and other useful information are presented in this documentation.

- Procedures are presented as numbered lists. A single bullet indicates that the procedure has only one step.
- Bold type is used for the following:
 - Keyboard entries that should be typed in their entirety exactly as shown. For example, “**copy file1**” means you must type the word **copy**, then type a space, and then type **file1**.
 - On-screen prompts and messages, names of options and text boxes, and menu commands. Menu commands are often separated by greater than signs (>). For example, “click **HFSS > Excitations > Assign > Wave Port.**”
 - Labeled keys on the computer keyboard. For example, “Press **Enter**” means to press the key labeled **Enter**.
- Italic type is used for the following:
 - Emphasis.
 - The titles of publications.
 - Keyboard entries when a name or a variable must be typed in place of the words in italics. For example, “**copy filename**” means you must type the word **copy**, then type a space, and then type the name of the file.
- The plus sign (+) is used between keyboard keys to indicate that you should press the keys at the same time. For example, “Press Shift+F1” means to press the **Shift** key and, while holding it down, press the **F1** key also. You should always depress the modifier key or keys first (for example, Shift, Ctrl, Alt, or Ctrl+Shift), continue to hold it/them down, and then press the last key in the instruction.

Accessing Commands: *Ribbons*, *menu bars*, and *shortcut menus* are three methods that can be used to see what commands are available in the application.

- The *Ribbon* occupies the rectangular area at the top of the application window and contains multiple tabs. Each tab has relevant commands that are organized, grouped, and labeled. An example of a typical user interaction is as follows:

"Click **Draw > Line**"



This instruction means that you should click the **Line** command on the **Draw** ribbon tab. An image of the command icon, or a partial view of the ribbon, is often included with the instruction.

- The *menu bar* (located above the ribbon) is a group of the main commands of an application arranged by category such File, Edit, View, Project, etc. An example of a typical user interaction is as follows:

"On the **File** menu, click the **Open Examples** command" means you can click the **File** menu and then click **Open Examples** to launch the dialog box.

- Another alternative is to use the *shortcut menu* that appears when you click the right-mouse button. An example of a typical user interaction is as follows:

"Right-click and select **Assign Excitation> Wave Port**" means when you click the right-mouse button with an object face selected, you can execute the excitation commands from the shortcut menu (and the corresponding sub-menus).

Getting Help: Ansys Technical Support

For information about Ansys Technical Support, go to the Ansys corporate Support website, <http://www.ansys.com/Support>. You can also contact your Ansys account manager in order to obtain this information.

All Ansys software files are ASCII text and can be sent conveniently by e-mail. When reporting difficulties, it is extremely helpful to include very specific information about what steps were taken or what stages the simulation reached, including software files as applicable. This allows more rapid and effective debugging.

Help Menu

To access help from the Help menu, click **Help** and select from the menu:

- **[product name] Help** - opens the contents of the help. This help includes the help for the product and its *Getting Started Guides*.
- **[product name] Scripting Help** - opens the contents of the *Scripting Guide*.
- **[product name] Getting Started Guides** - opens a topic that contains links to Getting Started Guides in the help system.

Context-Sensitive Help

To access help from the user interface, press **F1**. The help specific to the active product (design type) opens.

You can press **F1** while the cursor is pointing at a menu command or while a particular dialog box or dialog box tab is open. In this case, the help page associated with the command or open dialog box is displayed automatically.

Table of Contents

Table of Contents	Contents-1
1 - Introduction	1-1
The Model	1-1
2 - Creating the Model	2-1
Launching 2D Extractor and Saving a New Project	2-1
Setting the Model Units of Measure	2-2
Drawing the Model	2-3
Drawing the Substrate	2-3
Drawing the Ground	2-9
Creating the Top Grounds	2-10
Creating the Trace	2-12
Assigning Conductors	2-13
3 - Setting Up an Analysis	3-1
Adding a Solution Setup	3-1
Adding a Frequency Sweep	3-3
Performing a Reduce Matrix Operation	3-5
Validating the Setup	3-6
4 - Running the Analysis	4-1
Solving for Admittance and Impedance	4-1
Generating Reporter Plots	4-4
R Matrix Plots	4-4
Conductance vs. Frequency Plot	4-7
Generating Field Plots	4-8
VectorE Field Plot	4-8
JrL Field Plot	4-10
Changing Overlay Visibility	4-12

Exporting a Circuit Model 4-13

Adding a Parametric Sweep 4-15

Running a Parametric Analysis 4-17

1 - Introduction

This Getting Started Guide leads you step-by-step through creating, solving, and analyzing the results of a parameterized 2D model.

This guide explains how to perform the following tasks in 2D Extractor:

- Drawing a geometric model
- Modifying a model's design parameters
- Assigning conductors
- Running Reduce Matrix operations
- Specifying solution settings for a design
- Validating a design's setup
- Running a 2D Extractor simulation
- Plotting results

The Model

The model consists of a central rectangle and three thin rectangular copper conductors on top, and one long conductor on the bottom.

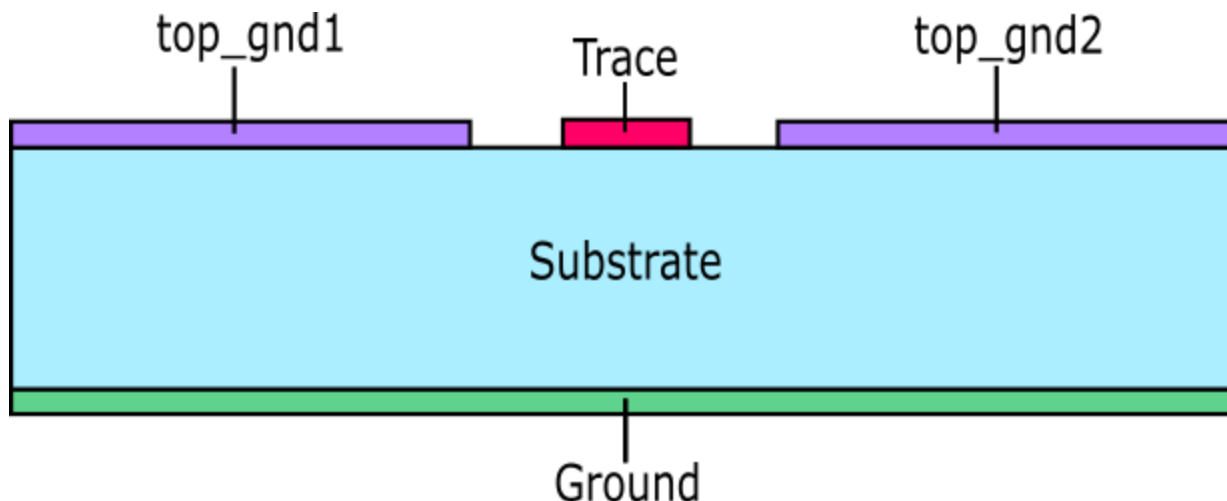

A copy of this model is located in the \AnsysEM installation folder under \[Release#]\Examples\2D Extractor.

In the following sections, you will recreate this model, analyze it, perform a reduce matrix operation, run a frequency sweep, run a parametric sweep, and plot the results.

2 - Creating the Model

This section explains how to perform the following tasks:

- Launching 2D Extractor and saving a new project
- Setting the units of measure for the design
- Drawing the model
- Assigning conductors

Launching 2D Extractor and Saving a New Project

A project is a collection of one or more designs that is saved in a single file. A new project is automatically created when 2D Extractor is launched. Open 2D Extractor and save the default project under a new name.

1. Launch **Ansys Electronics Desktop**.
2. Click **New** to create a new, empty project.

The project appears in the Project Manager, with the default name **Project#**. The number depends on the number of projects already in existence.

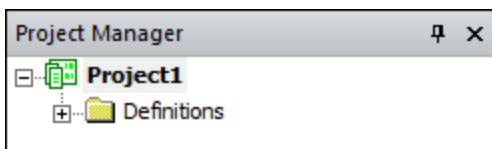

Project definitions, such as material assignments, are stored in the **Definitions** folder under the project name.

3. Click **Project > Insert 2D Extractor Design**.

An empty 2D Extractor design appears in the Project Manager:

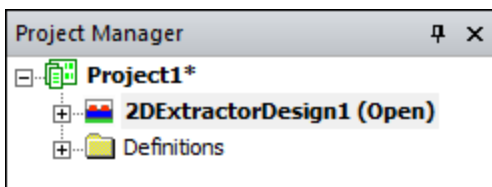

4. Click **File > Save As**.

The **Save As** window appears.

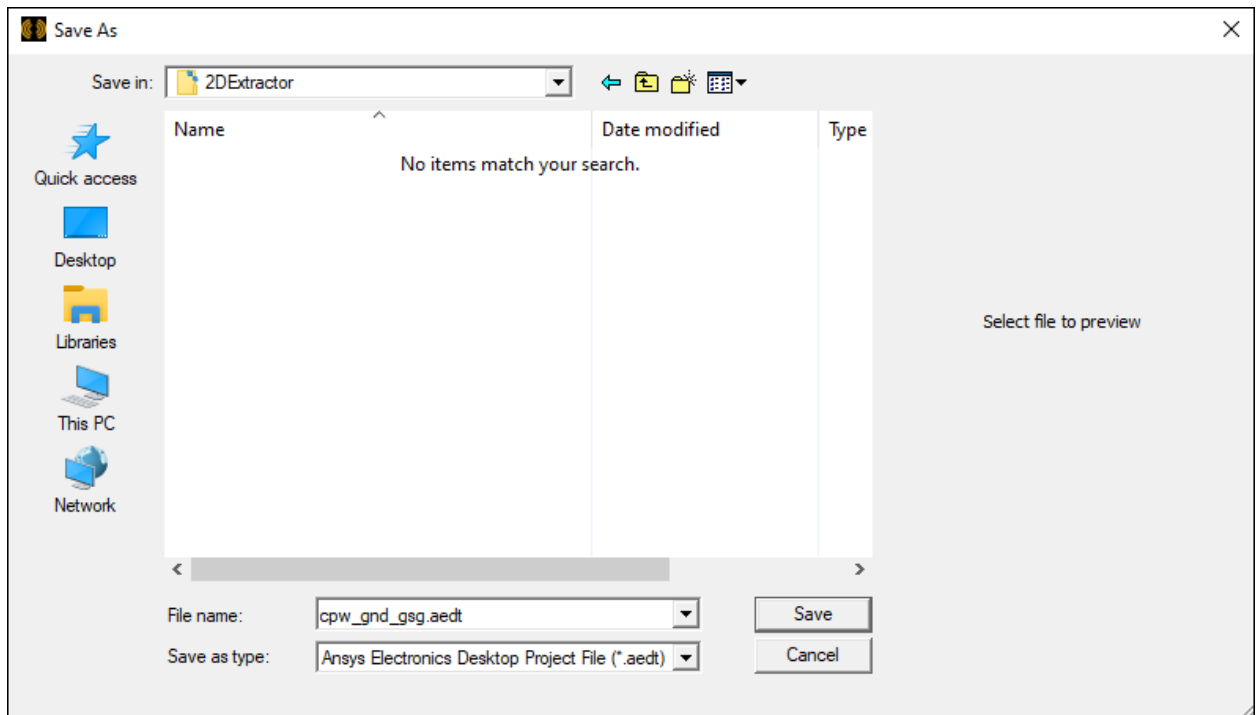

5. Locate a folder in which you want to save the project.
6. In the **File Name** field, type **cpw_gnd_gsg.aedt**.
7. Click **Save**.

The file cpw_gnd_gsg.aedt is saved to the folder you selected.

Setting the Model Units of Measure

Set the units of measurement for drawing the geometric model.

1. Click **Modeler > Units**.

The **Set Model Units** dialog box appears.

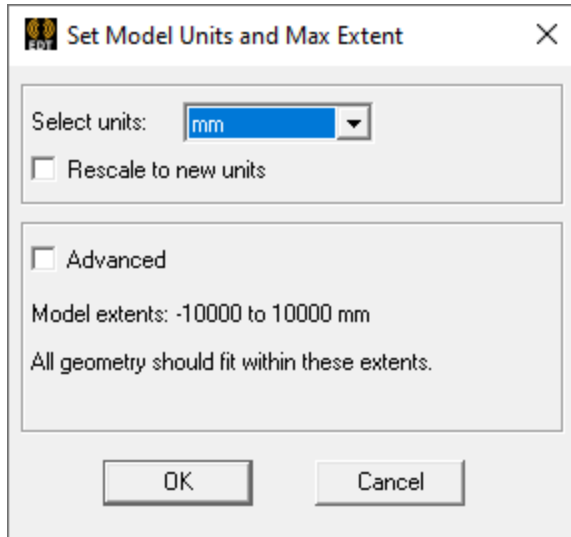

2. If it is not already selected, use the **Select units** drop-down menu to select **mm**.
3. Click **OK**.

Drawing the Model

Drawing the Substrate

Perform the following steps:

1. Click **Draw > Rectangle**.

The **Measure Data** dialog box appears, displaying the coordinates of the cursor in the Modeling area.

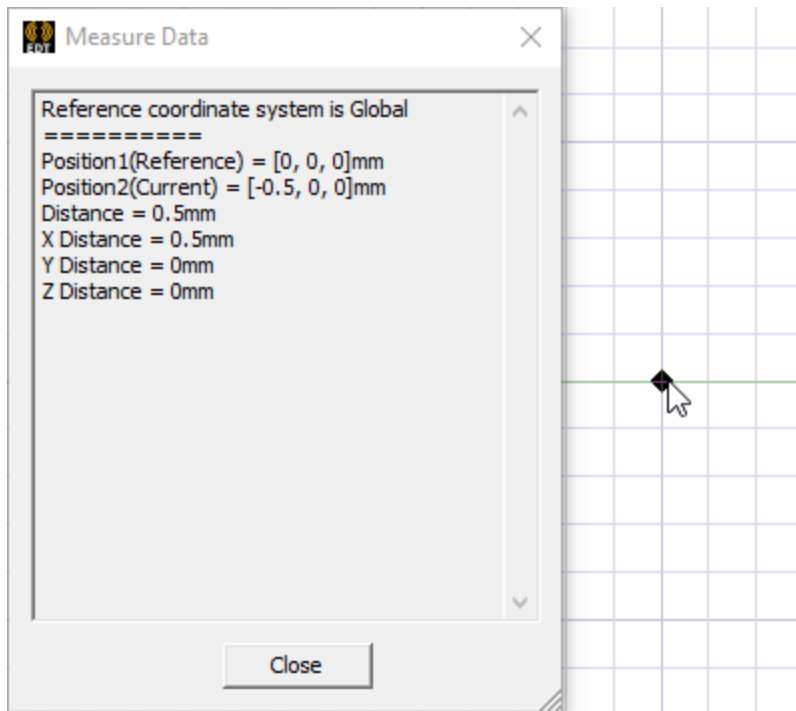

The current cursor position is displayed next to **Position2(Current)**.

2. Click to draw the lower-left corner of the rectangle at position (-0.5, 0, 0).
3. Click to draw the upper-right corner of the rectangle at position (0.5, 0.2, 0).

The rectangle is created. It appears in the Modeling area, and as **Rectangle1** in the History Tree.

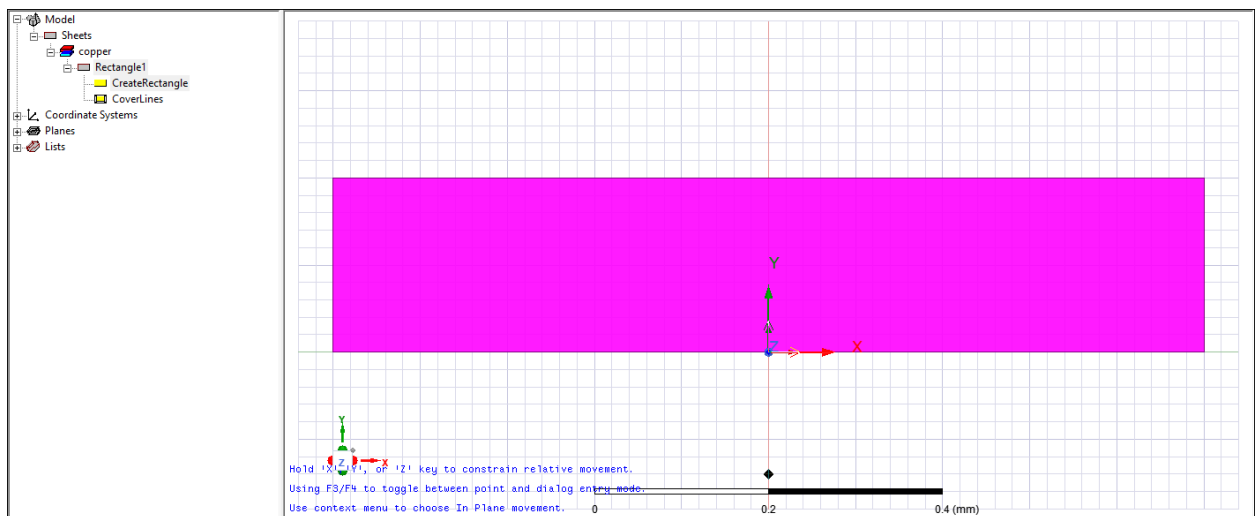

Important:

After its creation, the rectangle and the CreateRectangle action are selected in the History Tree by default.

If you have deselected them, ensure they are selected for the next steps.

4. From the **Properties** window, select the **Attribute** tab:

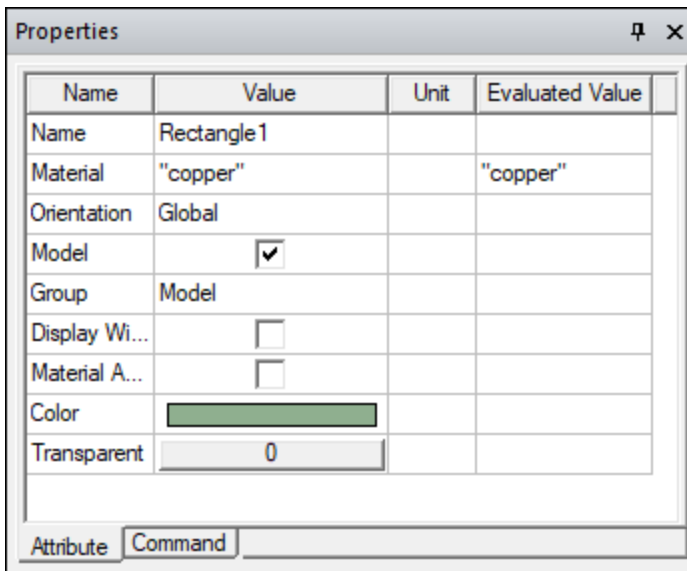

5. Click in the **Name | Value** field and rename **Rectangle1** to **Substrate**.
6. Press **Enter** to confirm the new name.
7. Select the **Command** tab.

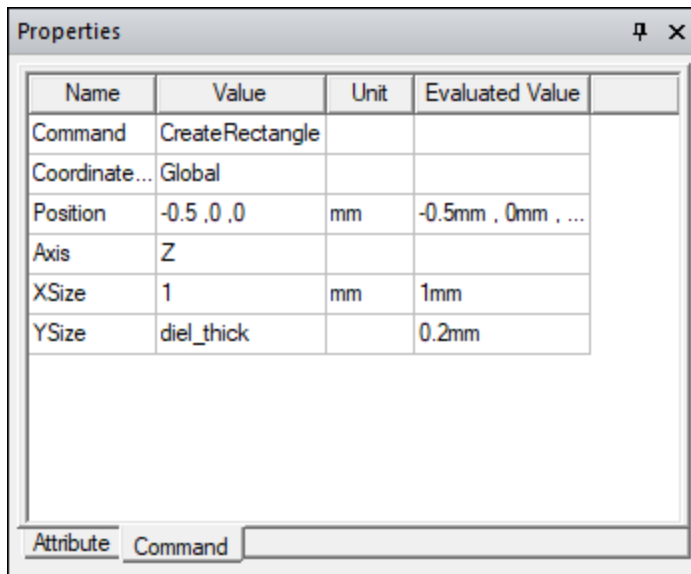

- In the **Ysize | Value** field, type **diel_thick** and press **Enter**.

The **Add Variable** dialog box appears.

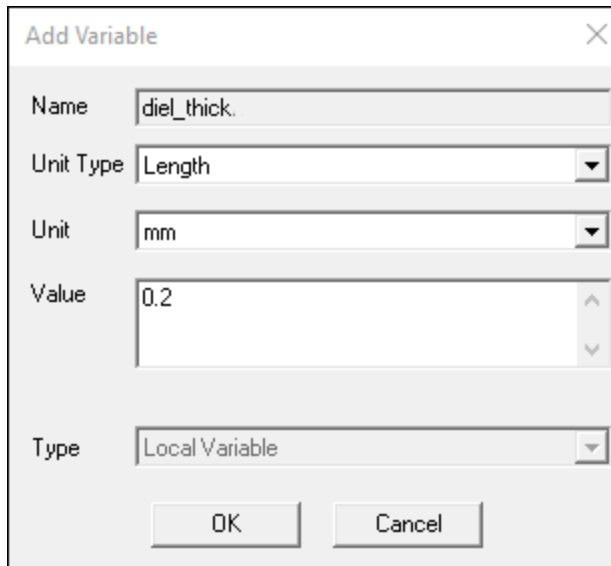

- From the **Unit Type** drop-down menu, select Length.
- From the **Unit** drop-down menu, select mm.
- In the **Value** field, enter 0.2.
- Click **OK**.

YSize is now defined as the local variable diel_thick.

13. From the **Properties** window, select the **Attribute** tab again.
14. Select the **Material | Value** field and use the drop-down menu to select **Edit**.

The **Select Definition** window appears.

15. Click **Add Material**.

The **View/Edit Material** window appears.

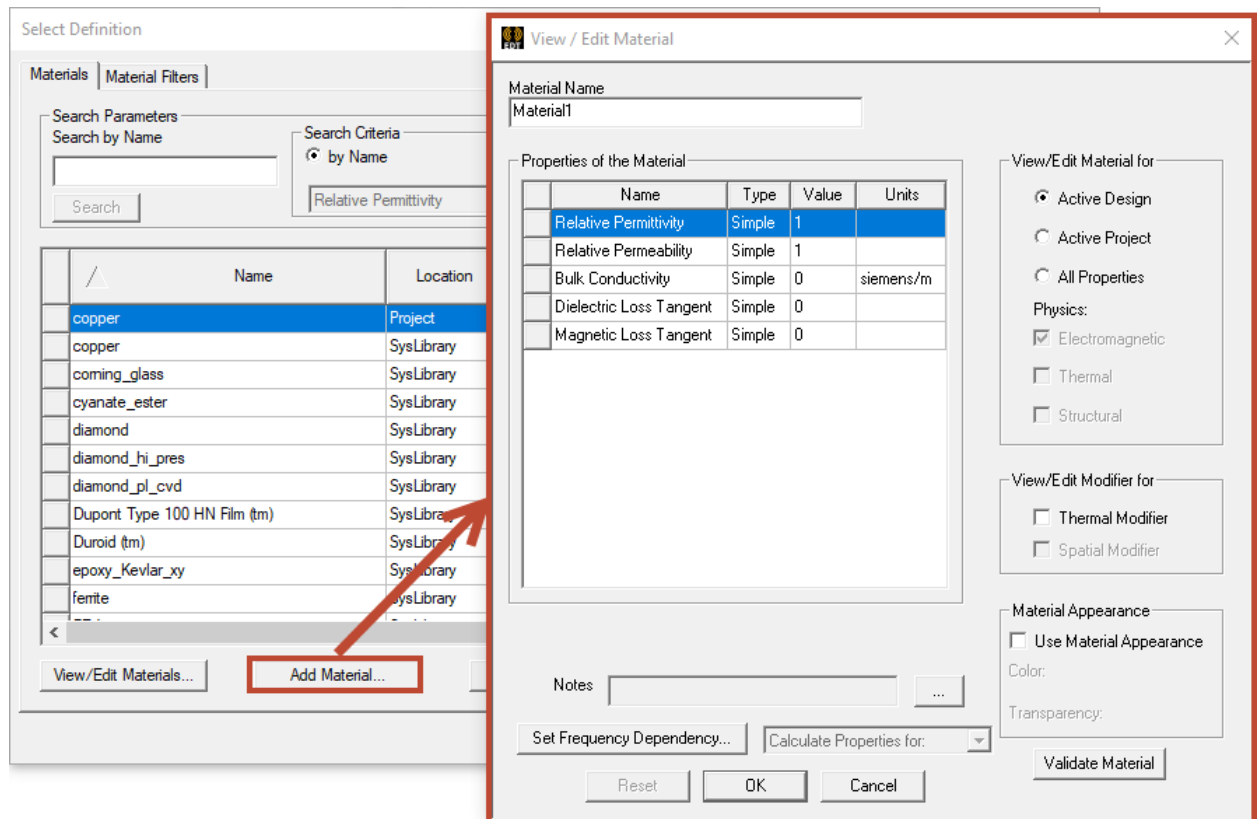

16. In the **Material Name** field, type **silicon_lossy**.
17. Click **Set Frequency Dependency**.

The **Frequency Dependent Material Setup Option** dialog box appears.

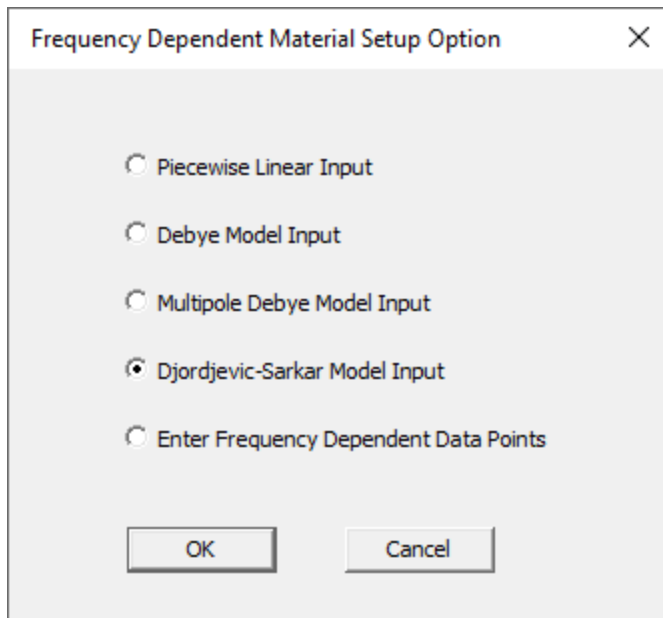

Djordjevic-Sarkar is the recommended frequency dependent material model as it ensures causality for subsequent time-domain simulations.

18. Select **Djordjevic-Sarkar Model Input** and click **OK**.

The **Djordjevic-Sarkar Model Input** window appears.

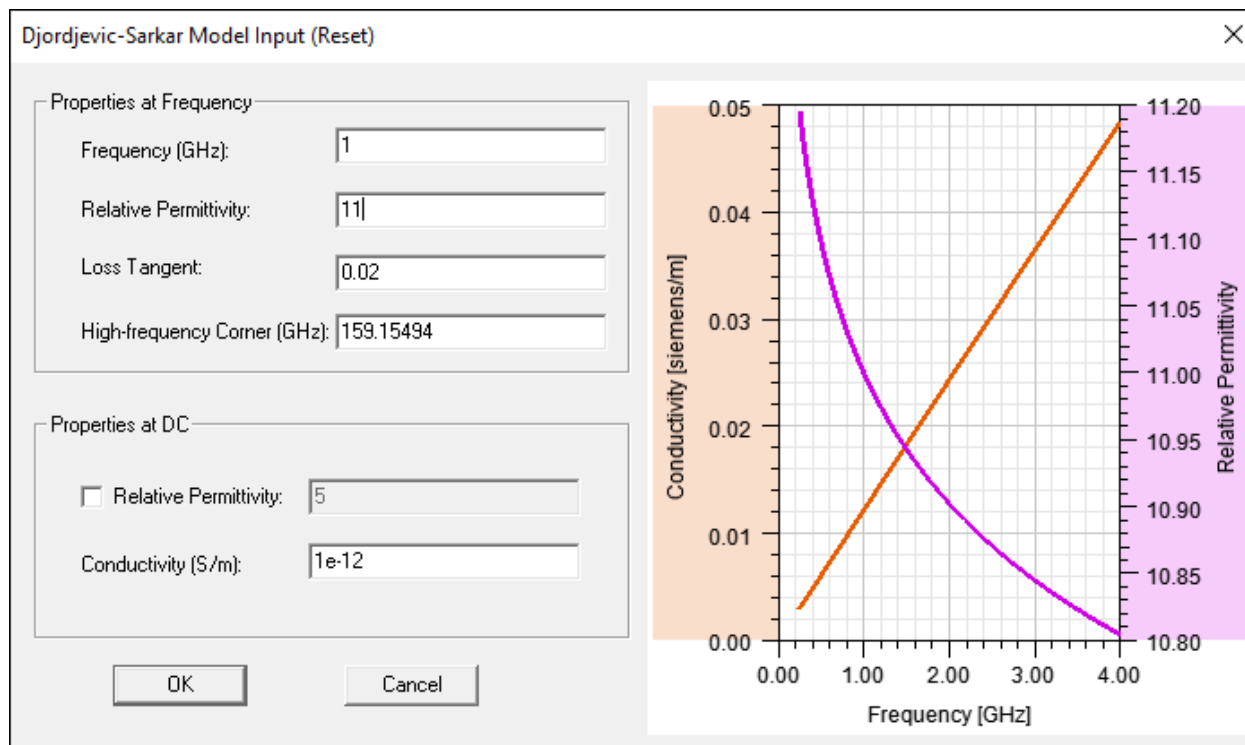

19. In the **Relative Permittivity** field, type **11**.
20. In the **Loss Tangent** field, type **0.02**.
21. Leave other fields as-is, and click **OK**.
22. Click **OK** three more times to return to the Modeling window.

Drawing the Ground

Now you will draw another rectangle at the base of **Substrate**.

1. Click **Draw > Rectangle**.

The **Measure Data** dialog box appears, displaying the coordinates of the cursor in the Modeling area.

2. Click to draw the upper-left corner of the rectangle at position (-0.5,0,0).
3. Click to draw the lower-right corner of the rectangle at position (0.5,-0.01,0).

Note:

You may need to zoom in on the Modeling area, either using the zoom options on the **View** tab or using your mouse's scroll wheel.

The rectangle is created as **Rectangle1**.

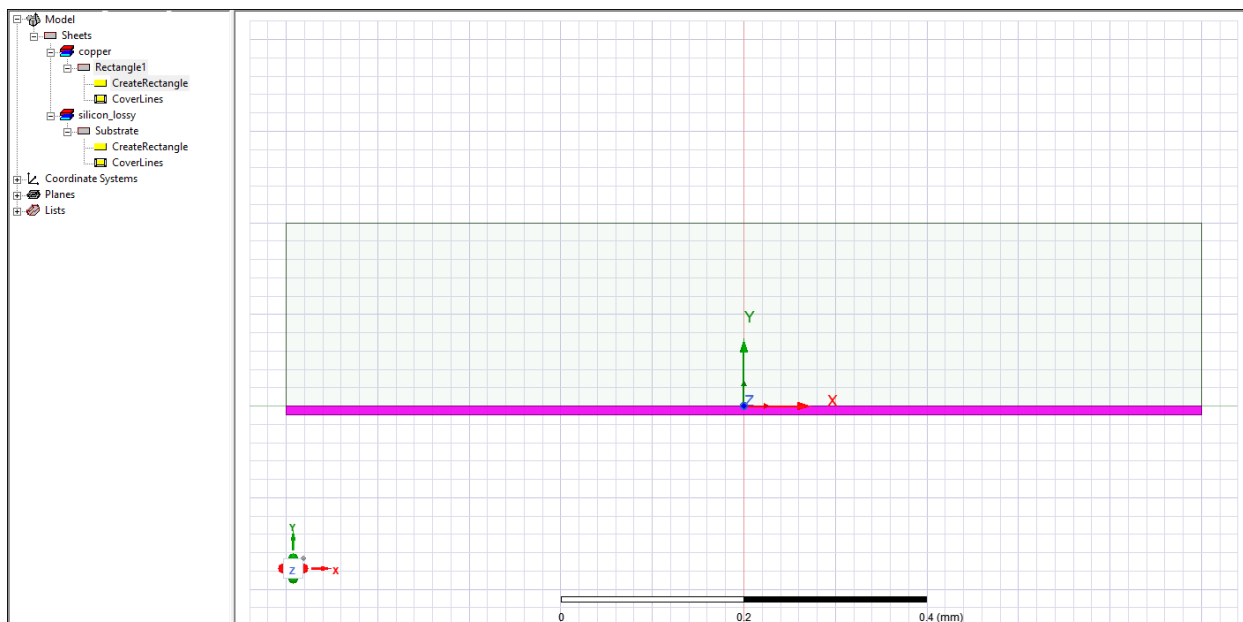

Important:

After its creation, the rectangle and the CreateRectangle action are selected in the History Tree by default.

If you have deselected them, ensure they are selected for the next steps.

4. From the **Properties** window, select the **Attribute** tab.
5. Click in the **Name | Value** field and rename **Rectangle1** to **Ground**.
6. Press **Enter** to confirm the new name.

Creating the Top Grounds

You will draw two more rectangles for ground planes:

1. Click **Draw > Rectangle**. Draw a rectangle of any size, anywhere in the Modeling workspace.

Important:

After its creation, the rectangle and the CreateRectangle action are selected in the History Tree by default.

If you have deselected them, ensure they are selected for the next steps.

2. On the **Attribute** tab, click in the **Name | Value** field and rename **Rectangle1** to **top_gnd1**.

3. Resize and reposition the rectangle using the **Command** tab in the **Properties** window.

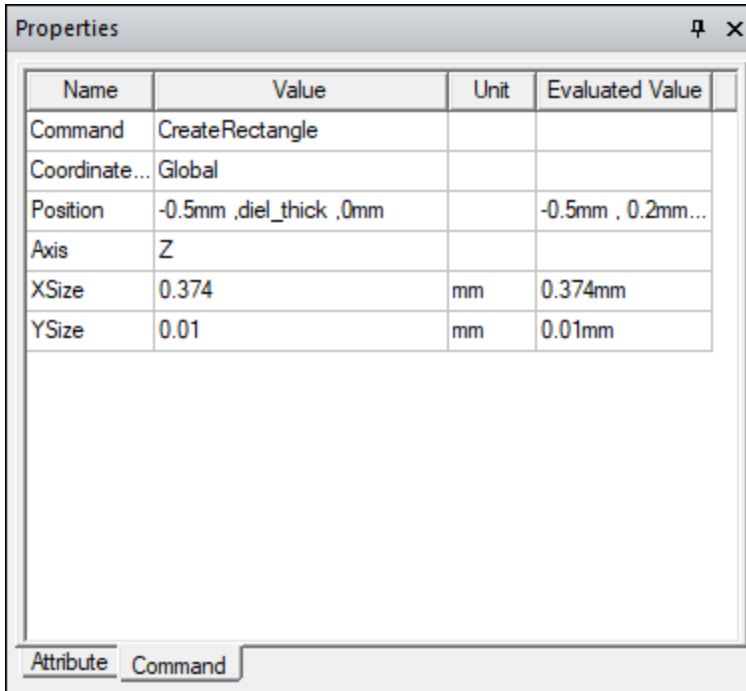

4. For the **Position | Value**, enter -0.5, diel_thick, 0.

The Y point is parameterized so that **top_gnd1** stays connected to **Substrate** as its thickness changes. You can see that diel_thick is translated to 0.2mm in the **Evaluated Value** field.

5. For the **XSize | Value**, enter 0.374.
6. For the **YSize | Value**, enter 0.01.

To create the second ground, you will duplicate this one.

1. Select **top_gnd1** and click **Edit > Duplicate > Mirror**.

The **Measure Data** dialog box appears.

2. Click the origin, then at any point along the X-axis to duplicate.

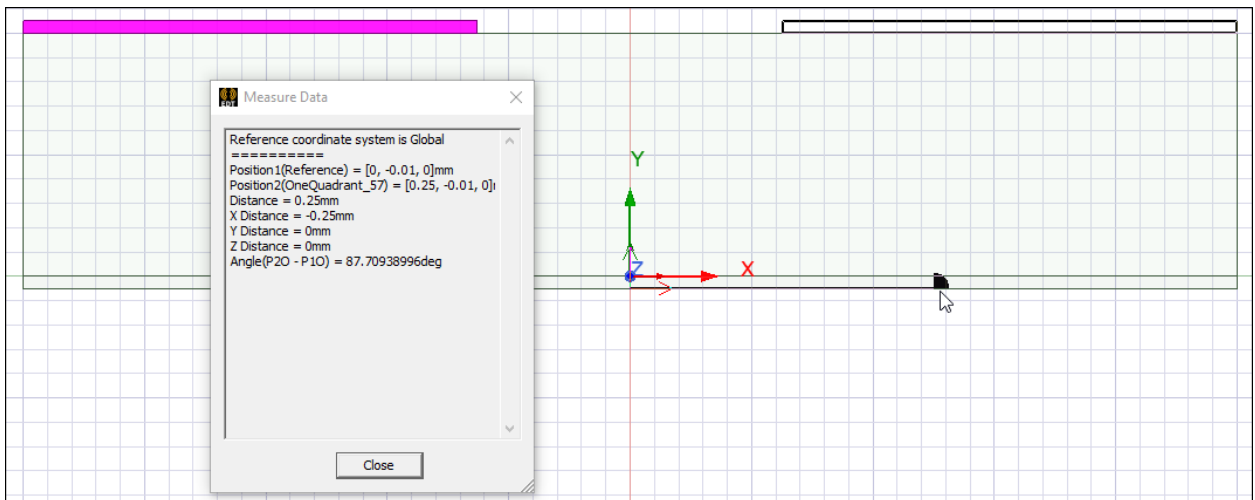
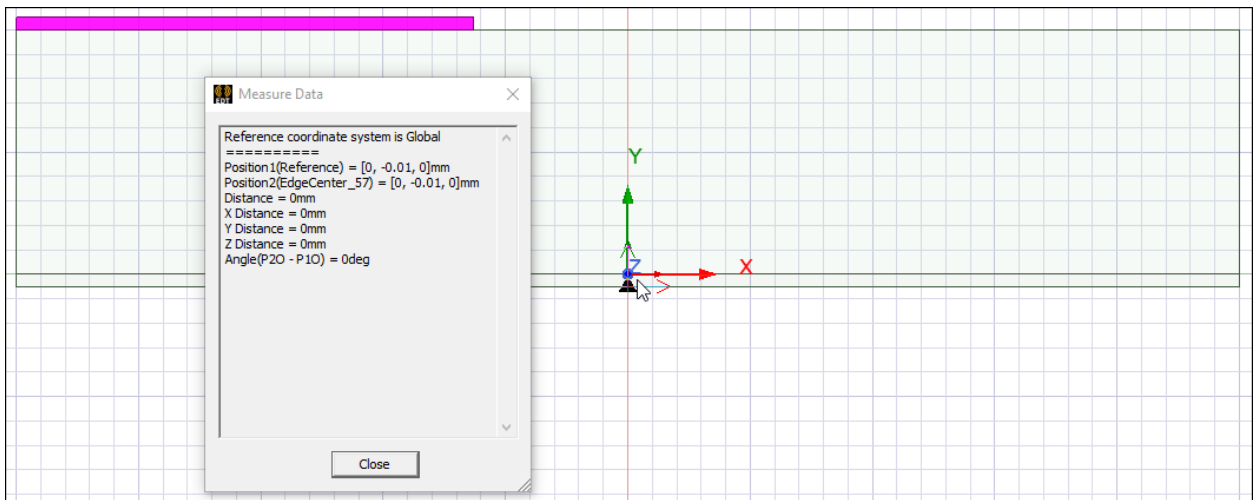

top_gnd1 is duplicated as **top_gnd1_1**.

3. Select **top_gnd1_1**.
4. In the **Properties** window, select the **Attributes** tab.
5. Rename **top_gnd1_1** to **top_gnd2**.

Creating the Trace

You will draw one final rectangle to represent a trace.

1. Click **Draw > Rectangle**. Place the rectangle anywhere in the Modeling workspace.

Rectangle1 is created.

Important:

After its creation, the rectangle and the CreateRectangle action are selected in the History Tree by default.

If you have deselected them, ensure they are selected for the next steps.

2. On the **Attribute** tab, click in the **Name | Value** field and rename **Rectangle1** to **trace**.
3. Resize and reposition the rectangle using the **Command** tab in the **Properties** window.
4. For the **Position | Value**, enter -0.05, diel_thick, 0.

The Y point is parameterized so the **trace** stays connected to **Substrate** as its thickness changes. You can see that diel_thick is translated to 0.2mm in the **Evaluated Value** field.

5. For the **XSize | Value**, enter 0.1.
6. For the **YSize | Value**, enter 0.01.

The project should look like this (colors have been changed for visibility):

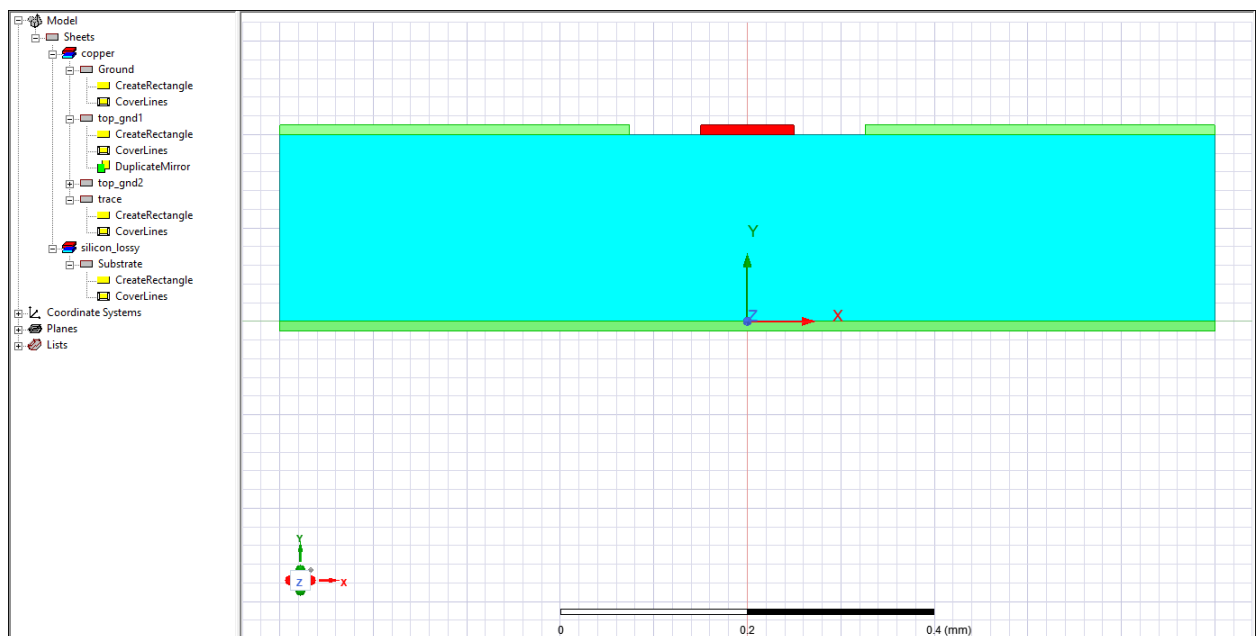

Assigning Conductors

Next, you will assign conductors.

1. Select **trace** and click **2D Extractor > Conductor > Assign > Signal Line**.

The **Signal Line** dialog box appears.

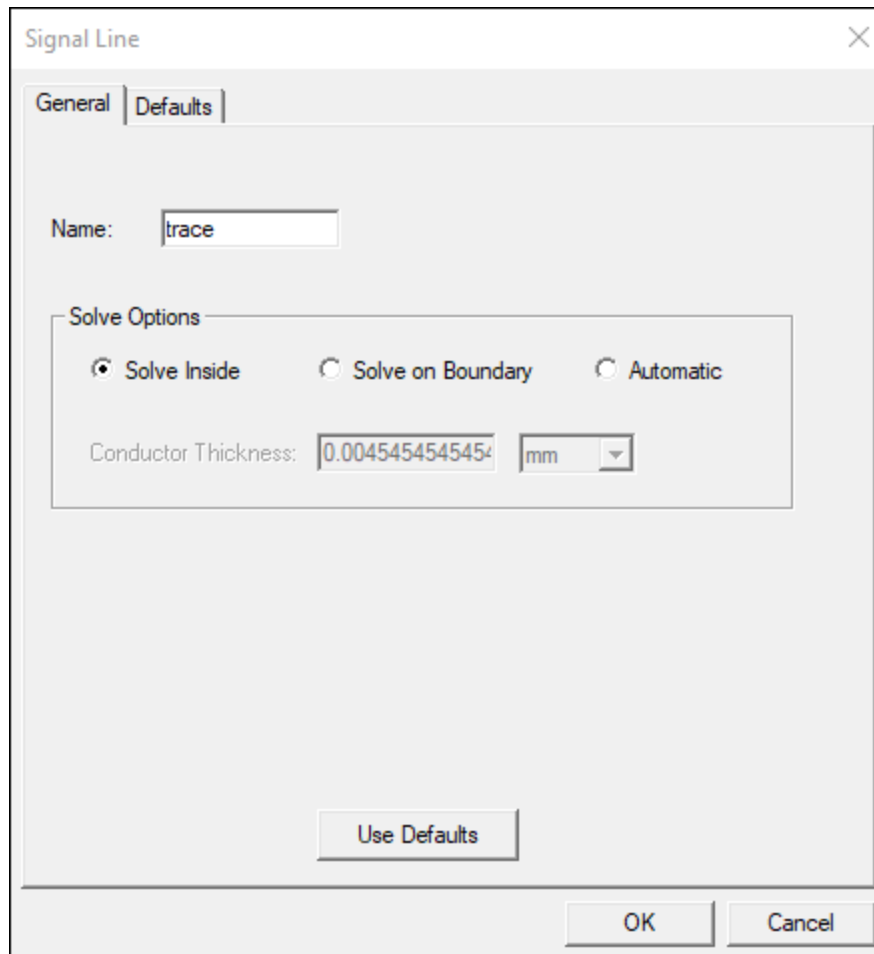

2. Leave the default values and click **OK** to return to the Modeling workspace.
3. Select **Ground** and click **2D Extractor > Conductor > Assign > Reference Ground**.

The **Reference Ground** dialog box appears.

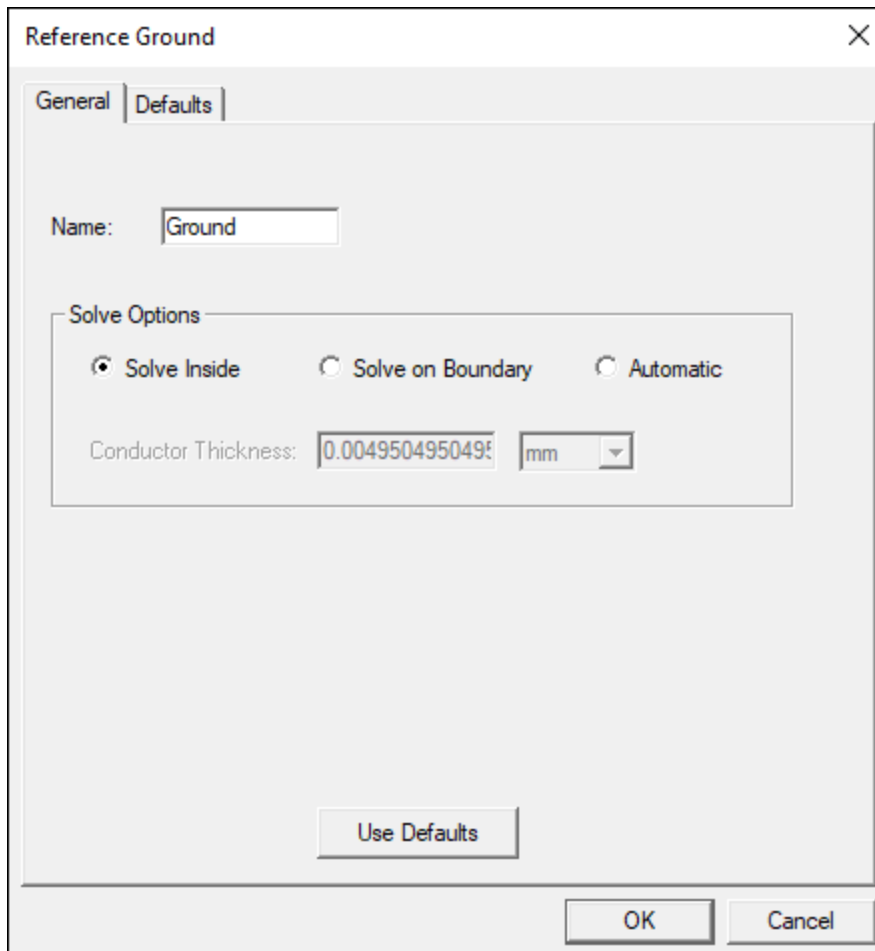

4. Leave the default values and click **OK** to return to the Modeling workspace.
5. **Ctrl + click** to select **top_gnd1** and **top_gnd2**, then click **2D Extractor > Conductor > Assign > Non Ideal Ground**.

The **Non Ideal Ground** window appears.

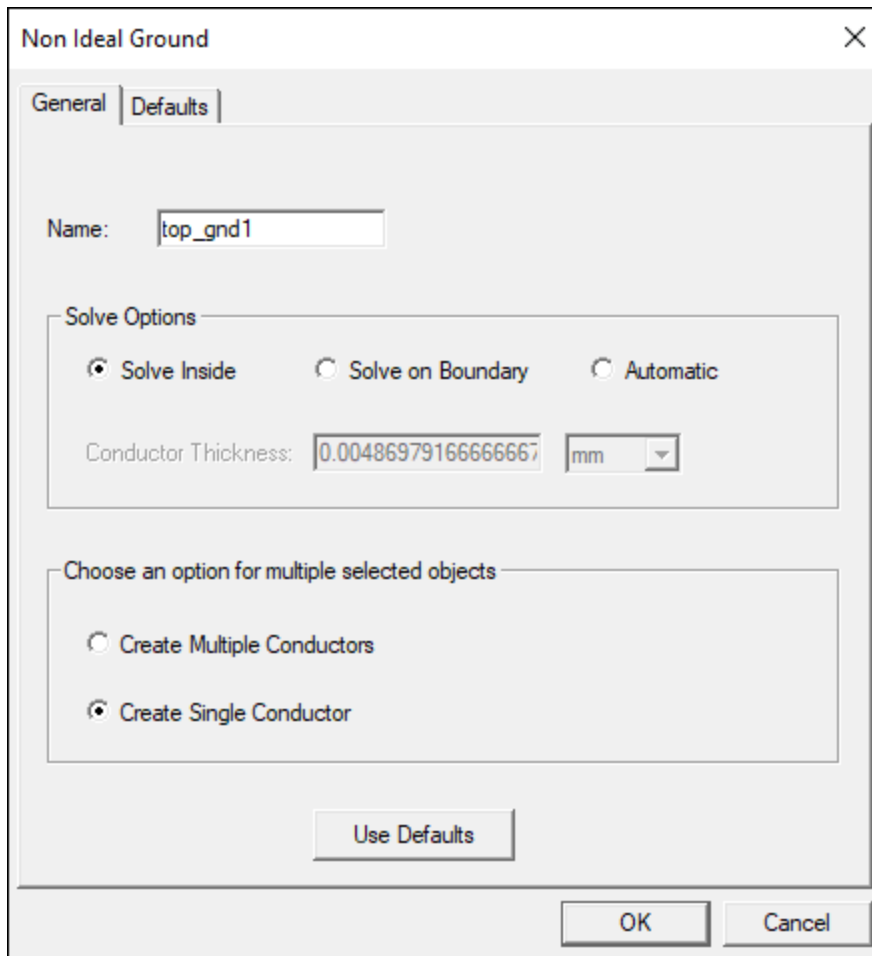

6. At the bottom of the window, select **Create Single Conductor**. Leave all other options as their default values.
7. Click **OK**.

This joins the two coplanar grounds in parallel, and concludes conductor assignment.

3 - Setting Up an Analysis

This section explains how to perform the following tasks:

- Adding a solution setup
- Adding a frequency sweep
- Performing a Reduce Matrix operation
- Validating the setup

Adding a Solution Setup

To add the solution setup:

1. Click **2D Extractor > Analysis Setup > Add Solution Setup**.

The **Solve Setup** window appears, on the **General** tab.

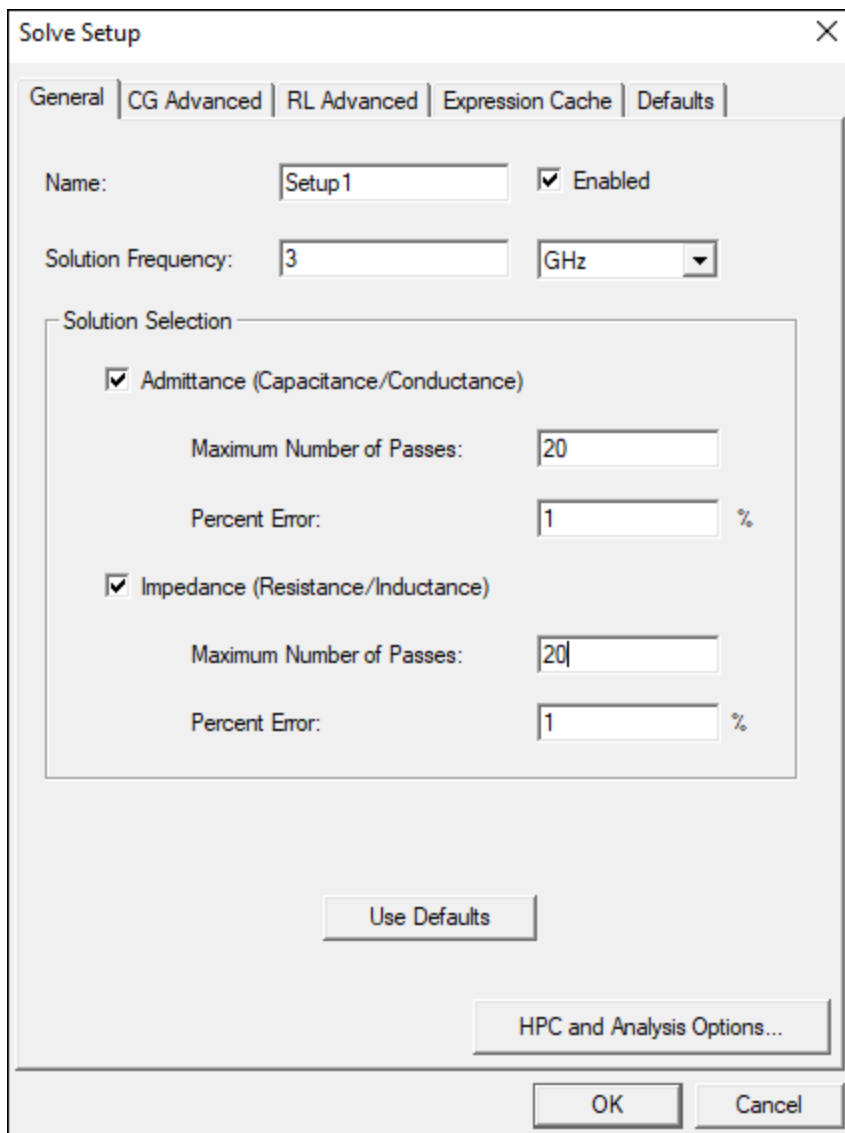

2. Adjust the settings, as follows:

- On the **General** tab:
 1. Verify that the **Solution Frequency** is set to **3 GHz**.
 2. Ensure the **Admittance (Capacitance/Conductance)** check box is selected.
 3. Ensure the **Impedance (Resistance/Inductance)** check box is selected.
 4. In *both* **Maximum Number of Passes** fields, enter **20**.
- On the **CG Advanced** tab:
 1. In the **Minimum Converged Passes** field, enter **2**.
 2. Ensure the **Use Loss Convergence** check box is selected.
- On the **RL Advanced** tab:

1. In the **Minimum Converged Passes** field, enter **2**.
2. Ensure the **Use Loss Convergence** check box is selected.
3. Leave all other settings as their defaults, and click **OK**.

The setup is listed as **Setup1** in the **Project Manager** under **Analysis**.

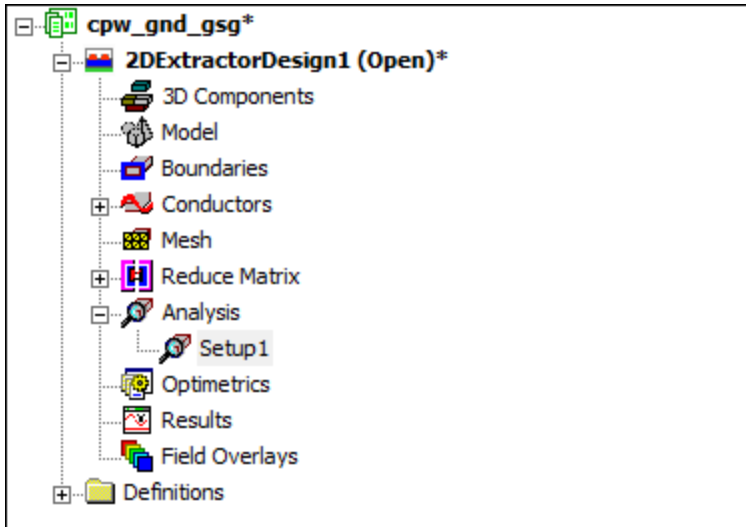

Adding a Frequency Sweep

Next, add a frequency sweep:

1. Click **2D Extractor > Analysis Setup > Add Frequency Sweep**.

The **Select** dialog box appears.

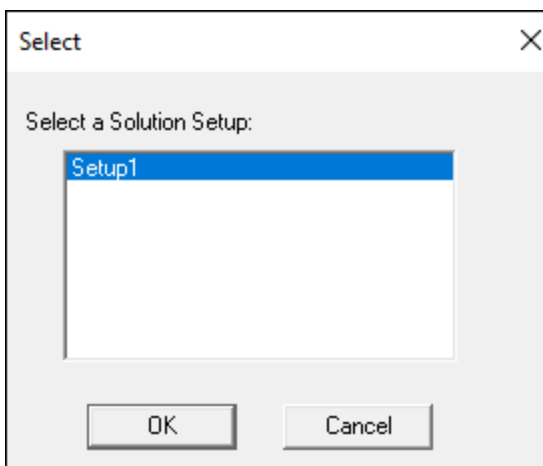

2. Select **Setup1** and click **OK**.

The **Edit Frequency Sweep** window appears.

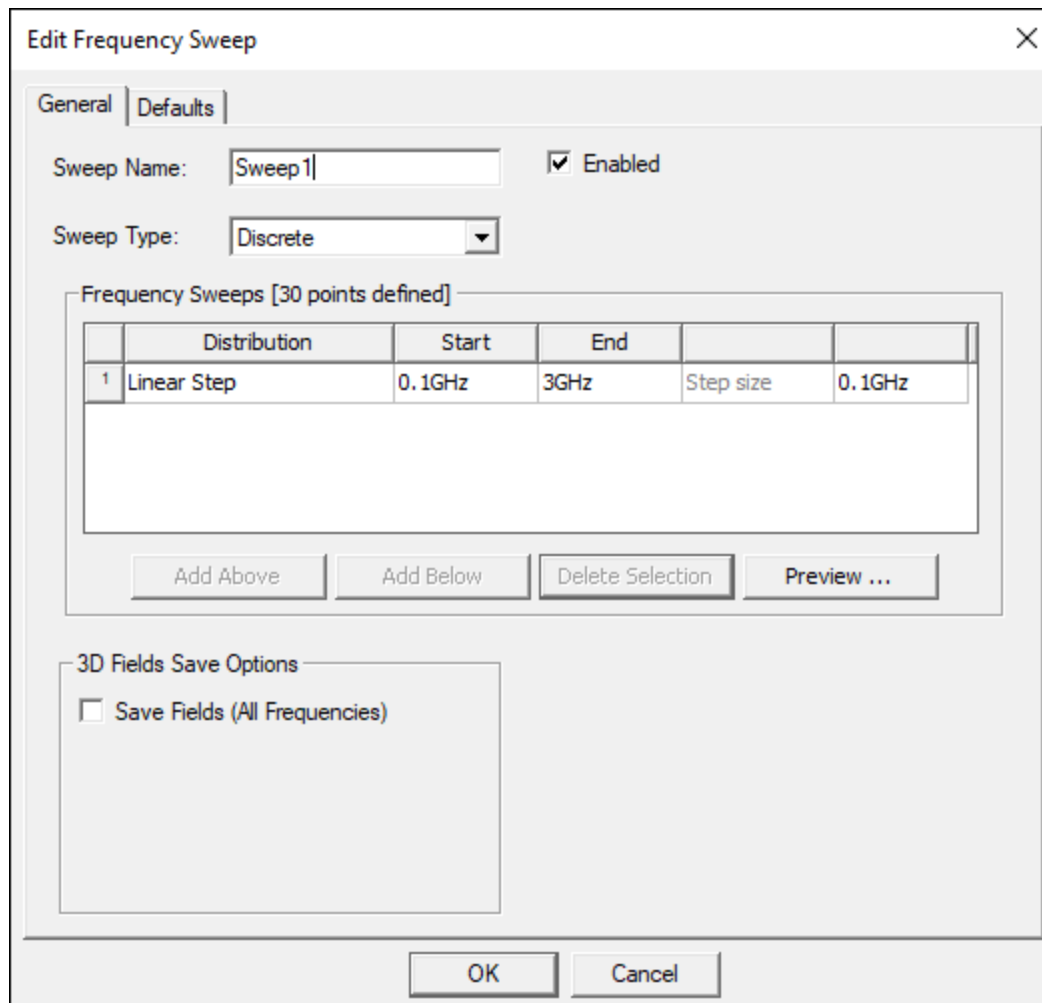

3. Use the **Delete Selection** button to remove all but one row.
4. Edit the remaining row. Use the **Distribution** drop-down menu to select **Linear Step**.
5. Adjust the settings as follows:
 - In the **Start** box, enter **0.1 GHz**.
 - In the **Stop** box, enter **3 GHz**.
 - In the **Step Size** box, enter **0.1 GHz**.
6. Click **OK**.

The frequency sweep is listed as **Sweep1** in the **Project Manager** under **Setup1**

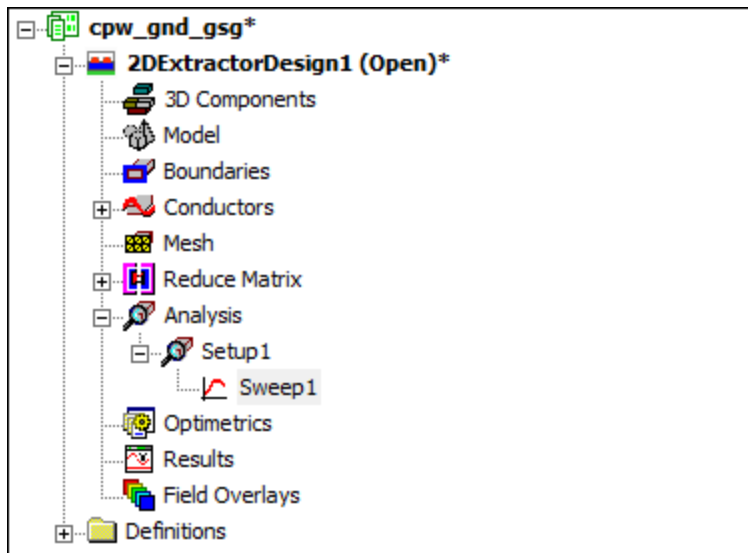

Performing a Reduce Matrix Operation

Perform a Reduce Matrix operation:

1. Click **2D Extractor > Reduce Matrix > Add Ground**.

The **Reduce Operation** window appears.

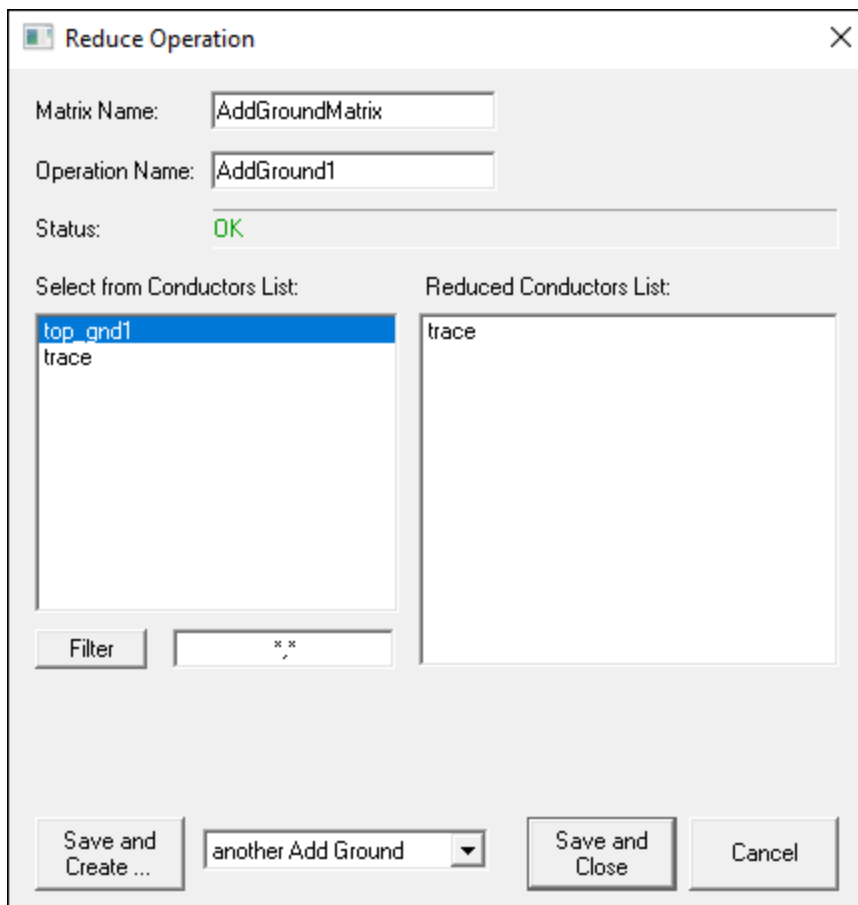

2. In the **Select from Conductors List** table, select **top_gnd1**.

This ties the objects top_gnd1, top_gnd2 and Ground in parallel and treats them as the reference ground.

3. Click **Save and Close**.

Validating the Setup

Before solving, you must verify that all the steps have been properly completed.

1. Click **2D Extractor > Validation Check**.

The **Validation Check** window appears.

When the check has finished, the window reads "Validation Check completed."

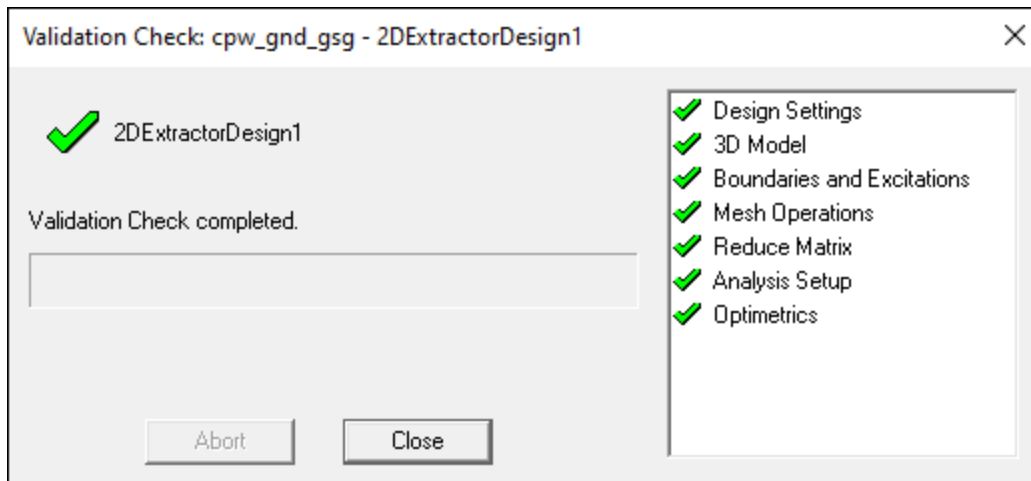

2. Verify that there is a green check mark next to each item.

Important:

If there are any errors, the window will display a red X next to the item in the list containing an error. Should that occur, go back and verify that you performed the previous steps correctly.

3. Click **Close**.

4 - Running the Analysis

This section explains how to perform the following tasks:

- Solving for Admittance and Impedance
- Generating Reporter plots
- Generating Field plots
- Exporting a Circuit model
- Adding a Parametric sweep
- Running a Parametric analysis

Solving for Admittance and Impedance

If you have no errors from the validation check, you are ready to launch the solvers.

To run the analysis that you set up earlier:

1. In the **Project Manager**, right-click **Setup1** and select **Analyze**.

The **Progress** window displays a progress bar.

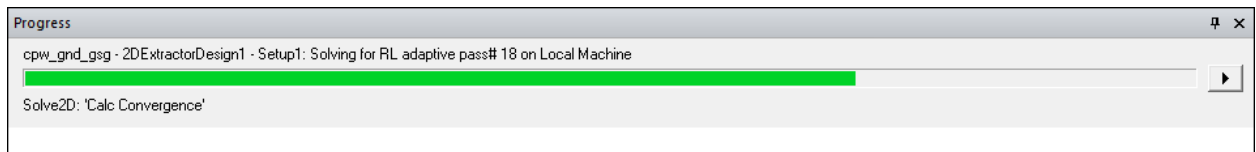

2. To view details about the simulation in progress, right-click **Setup1** and select **Convergence**.

The **Solutions** window appears, on the **Convergence** tab.

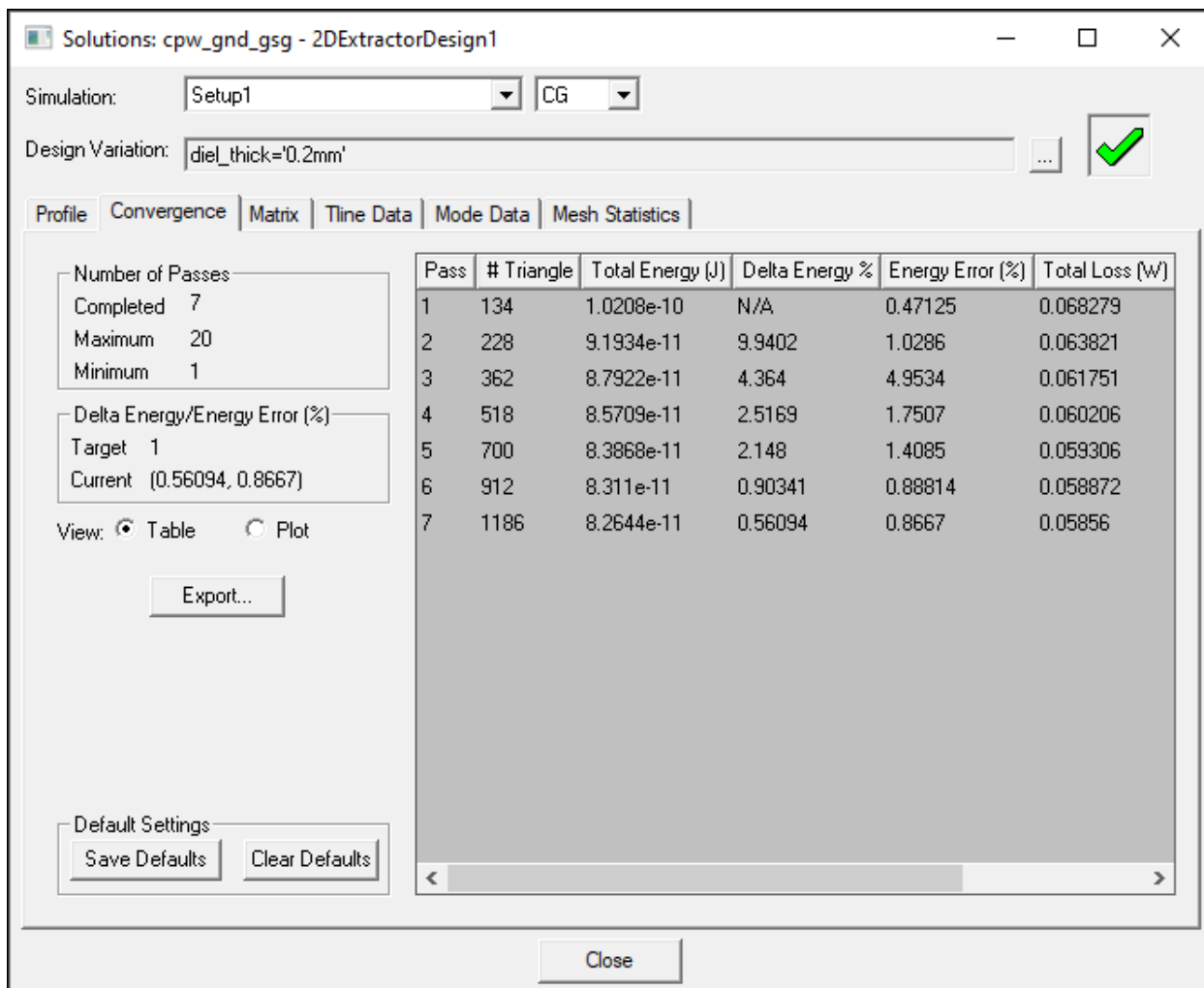

The table shows how the mesh grows from one adaptive solution pass to the next and how much the solution changes (delta%) between passes.

3. Use the **CG** drop-down menu to select **RL**.

Convergence information for the impedance solution displays.

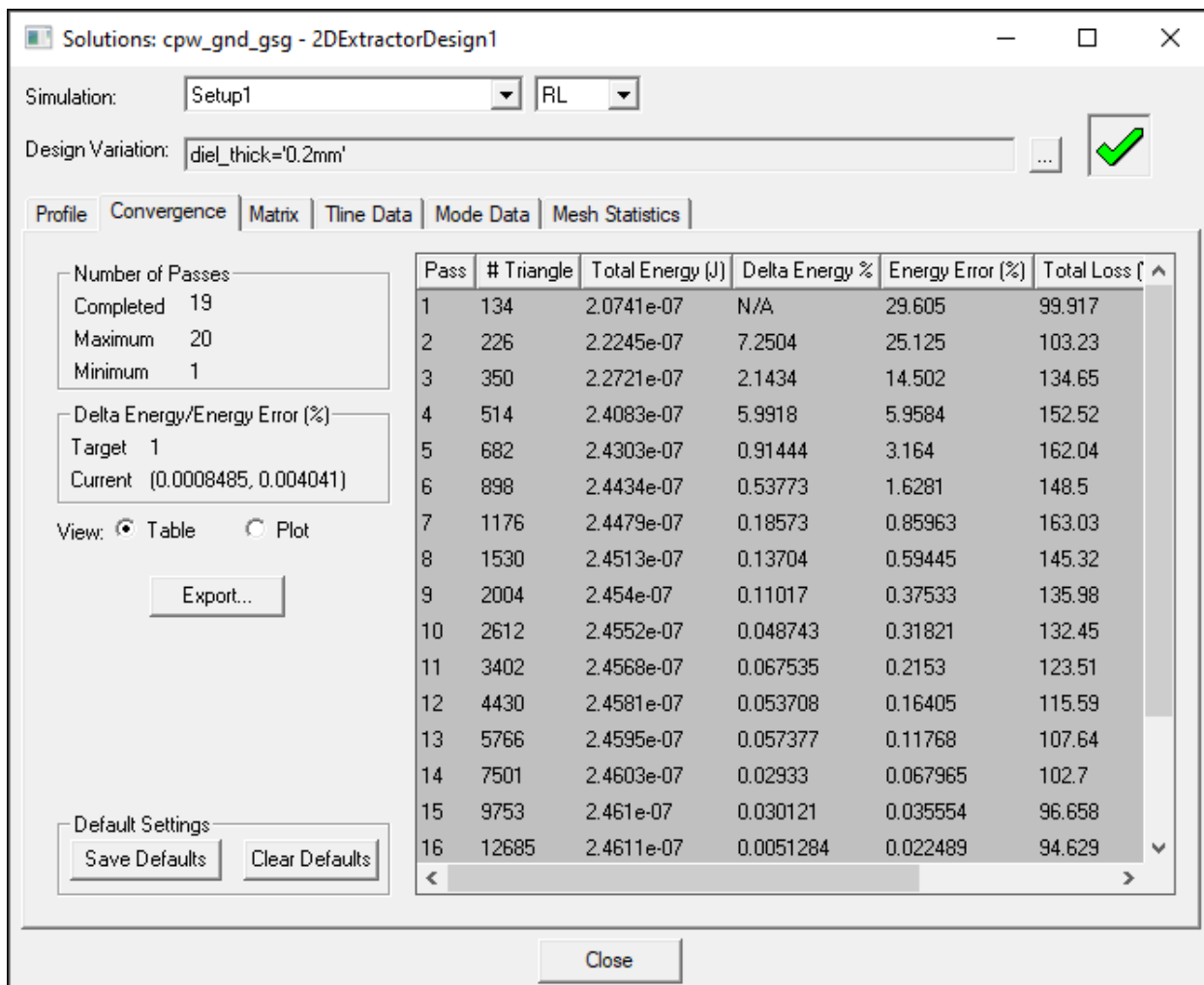

4. Select the **Matrix** tab.
5. Use the **Original** drop-down menu to select **AddGroundMatrix**.

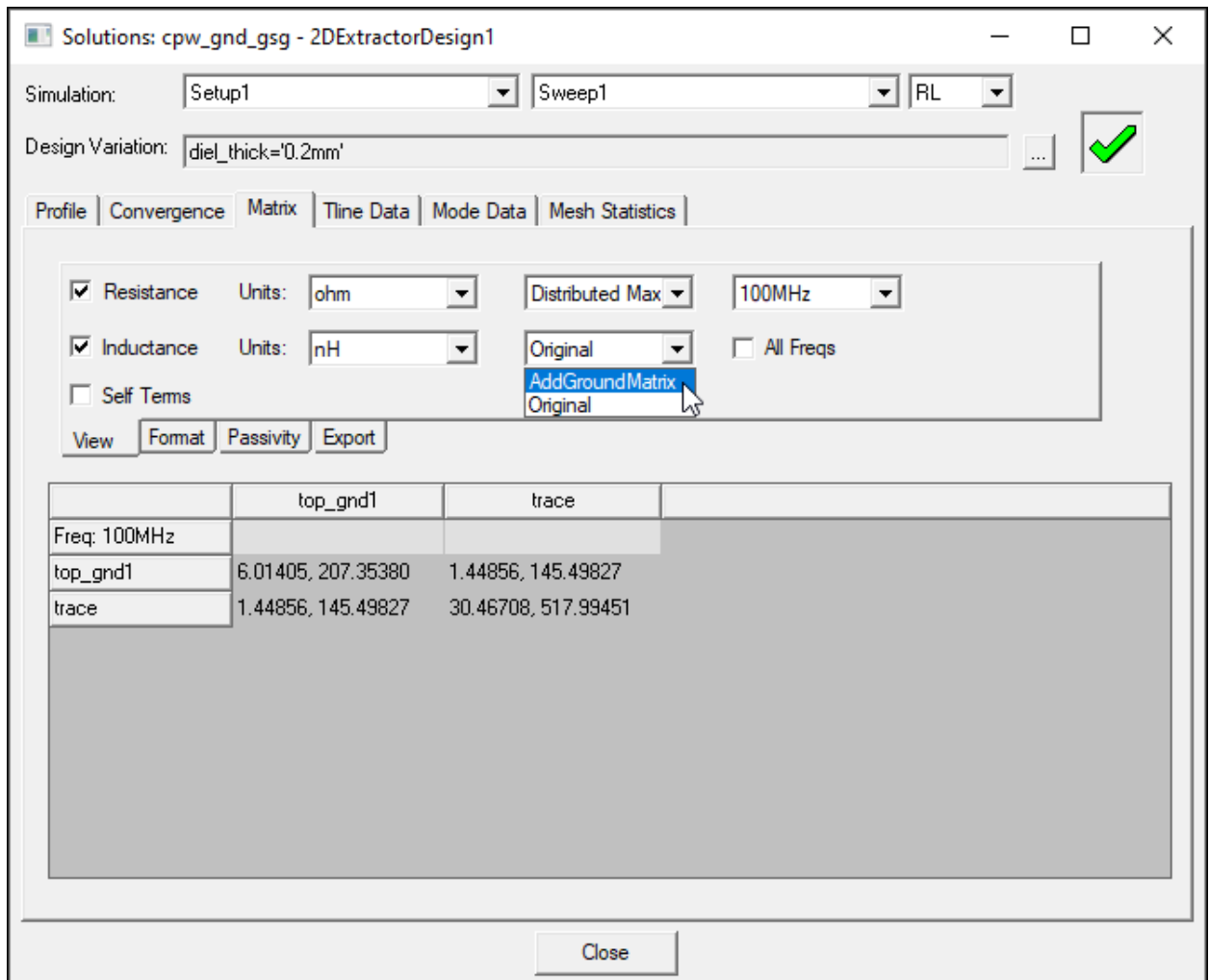

6. If desired, use the other tabs to view additional information:

- **Profile** – run-time profile information, such as the amount of CPU time or memory used in the solution.
- **Tline Data** – characteristic impedance and cross-talk coefficients.
- **Mode Data** – propagation data, such as velocity and attenuation.
- **Mesh Statistics** – mesh element information.

7. Click **Close**.

Generating Reporter Plots

R Matrix Plots

After running the simulation, you can view various plots.

First, view the resistance vs. frequency plot:

1. Click **2D Extractor > Results > Create Matrix Report > Rectangular Plot**.

The **Report** window appears.

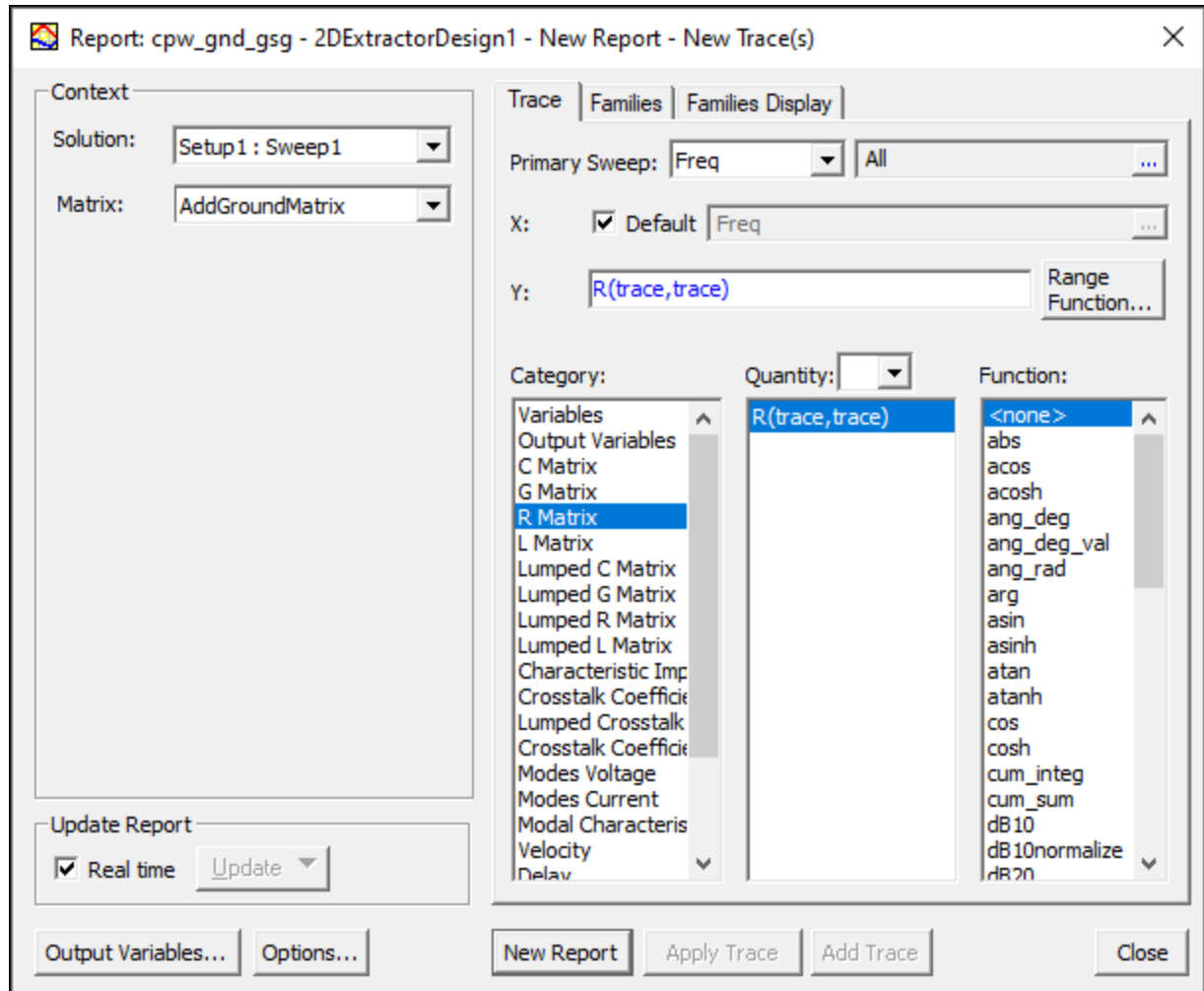

2. Use the **Solution** drop-down menu to ensure **Setup1:Sweep1** is selected.
3. Use the **Matrix** drop-down menu to select **AddGroundMatrix**.
4. In the **Category** list, select **R Matrix**.
5. In the **Quantity** list, select **R(trace,trace)**.
6. Leave the default values for all other fields, and click **New Report**.

The report appears as a plot in the Modeling workspace, and is listed under **Results** in the **Project Manager**.

Getting Started with Q3D Extractor®: A 2D Grounded Coplanar Waveguide Model

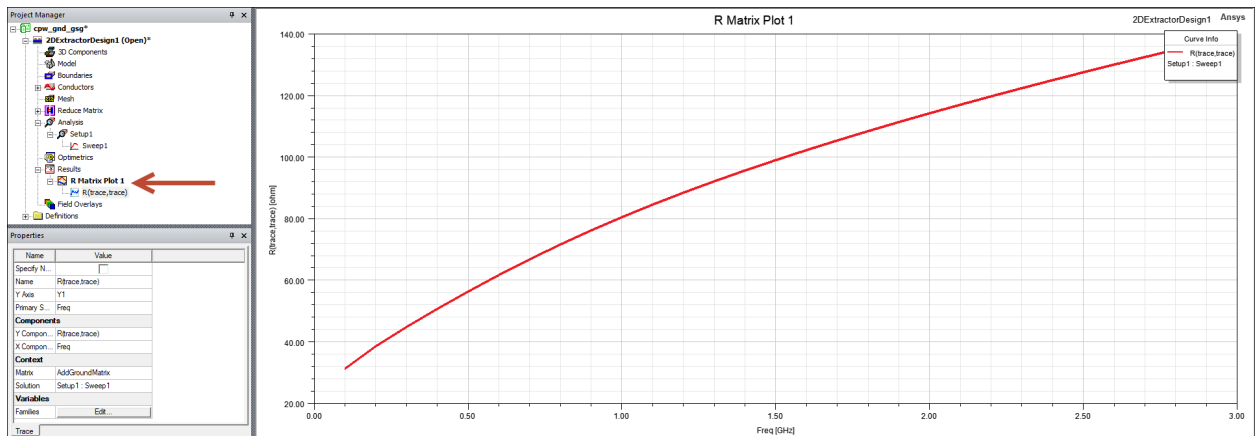

7. Click **Close** to close the **Report** window.

Change the plot to a logarithmic scale:

1. Double-click the X axis.

The **Properties** window appears.

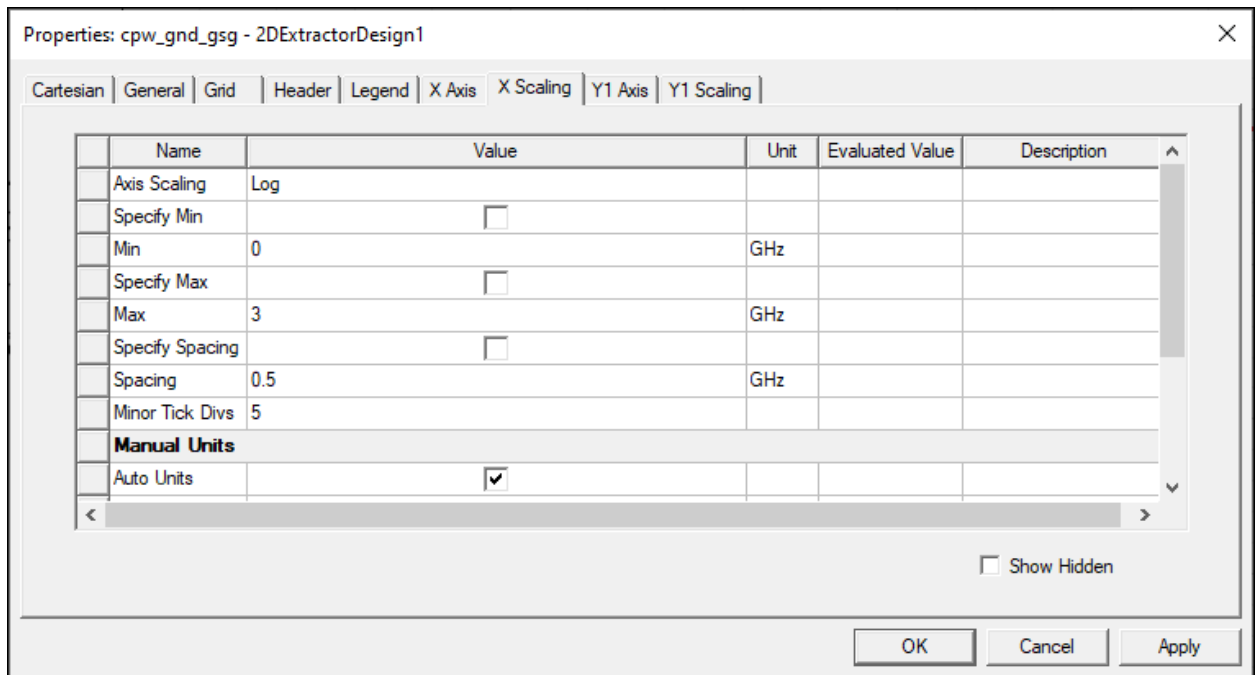

2. Select the **X Scaling** tab.

3. Use the **Axis Scaling | Value** drop-down menu to select **Log**.

4. Click **Apply** to update the report.

- Click **OK** to exit the **Properties** window and view the updated report.

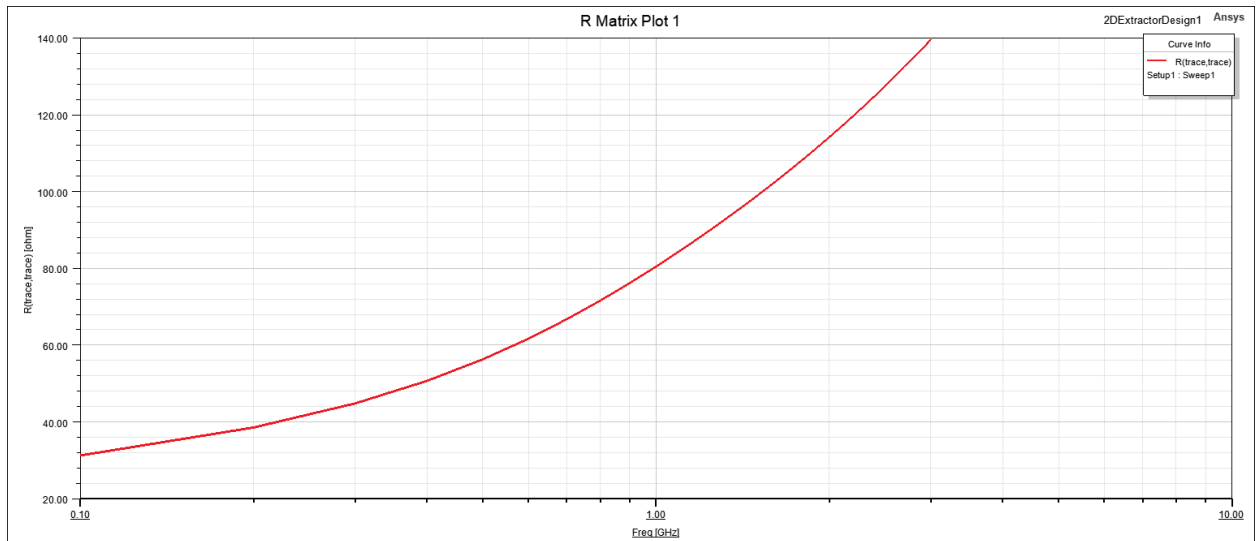

Conductance vs. Frequency Plot

Now you will generate a plot of conductance vs. frequency.

- Click **2D Extractor > Results > Create Matrix Report > Rectangular Plot**.
- Use the **Solution** drop-down menu to ensure that **Setup1:Sweep1** is selected.
- Use the **Matrix** drop-down menu to select **AddGroundMatrix**.
- In the **Category** list, select **G Matrix**.
- In the **Quantity** list, select **G(trace,trace)**.
- Leave the default values for all other fields, and click **New Report**.

7. Click **Close** to close the **Report** window and view the report.

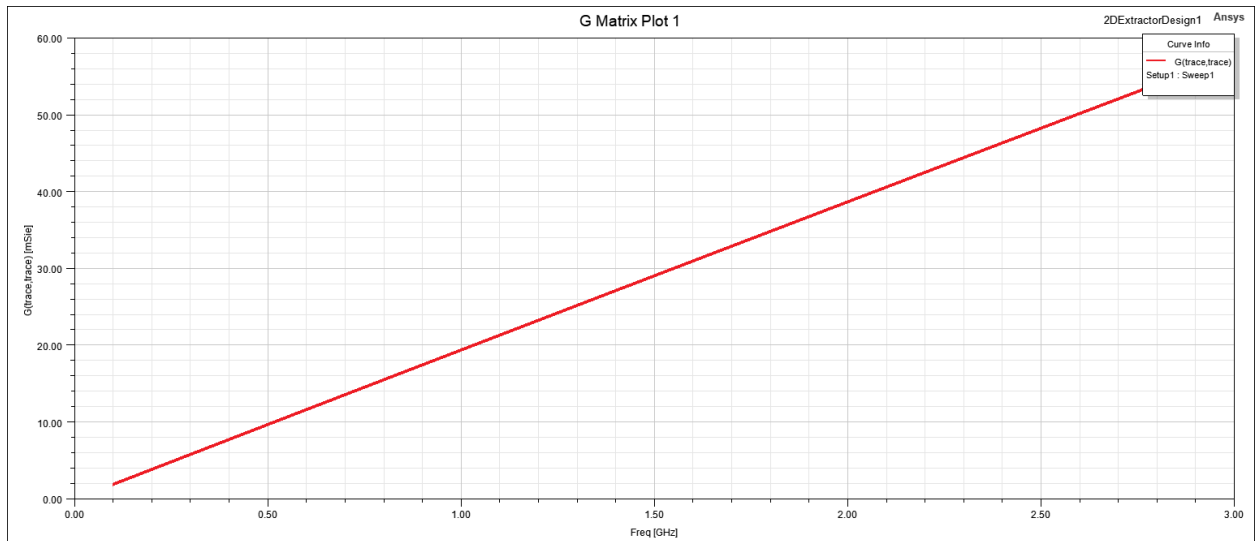

Generating Field Plots

VectorE Field Plot

Field plots represent basic or derived quantities on surfaces of objects.

You will plot Vector E for CG:

1. Return to the Modeling workspace by double-clicking **2DExtractorDesign1** in the **Project Manager**.
2. Select the **Substrate** object.
3. Click **2D Extractor > Fields > CG Fields > E > VectorE**.

The **Create Field Plot** window appears.

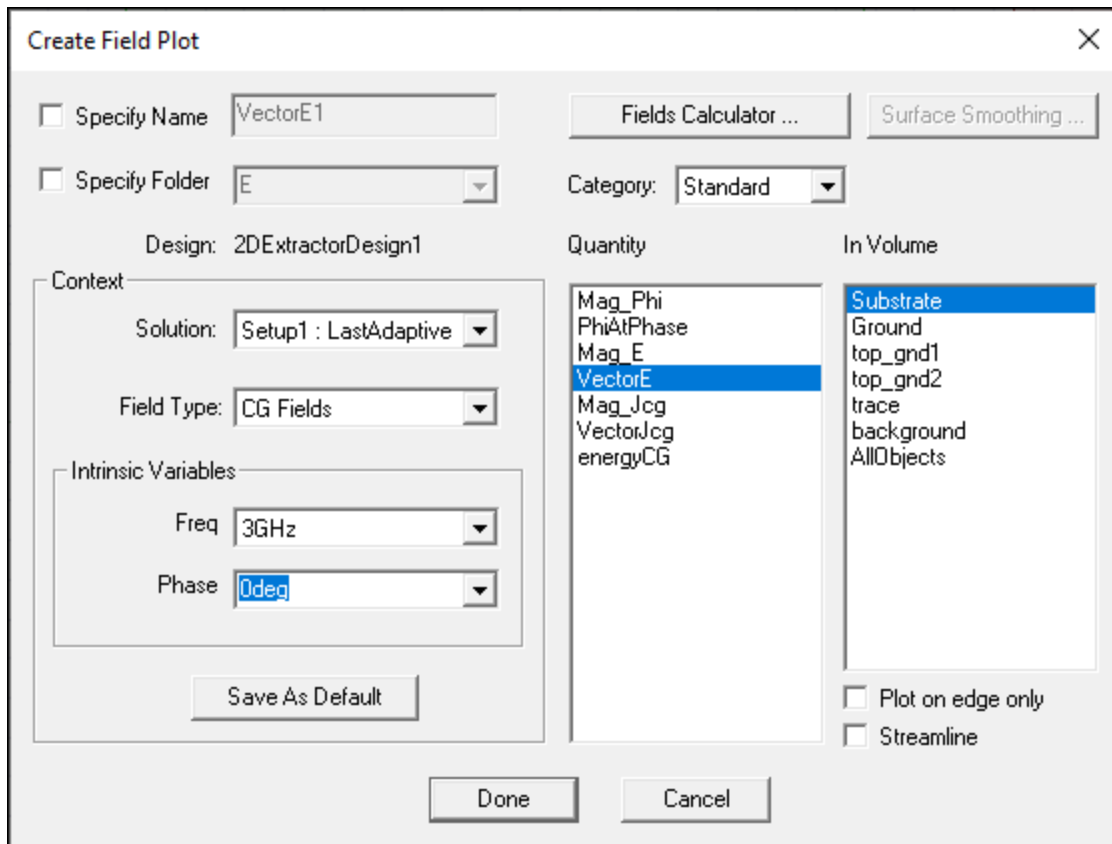

4. Use the **In Volume** list to select **Substrate**.
5. Leave the default values, and click **Done**.

The plot appears in the Modeling workspace.

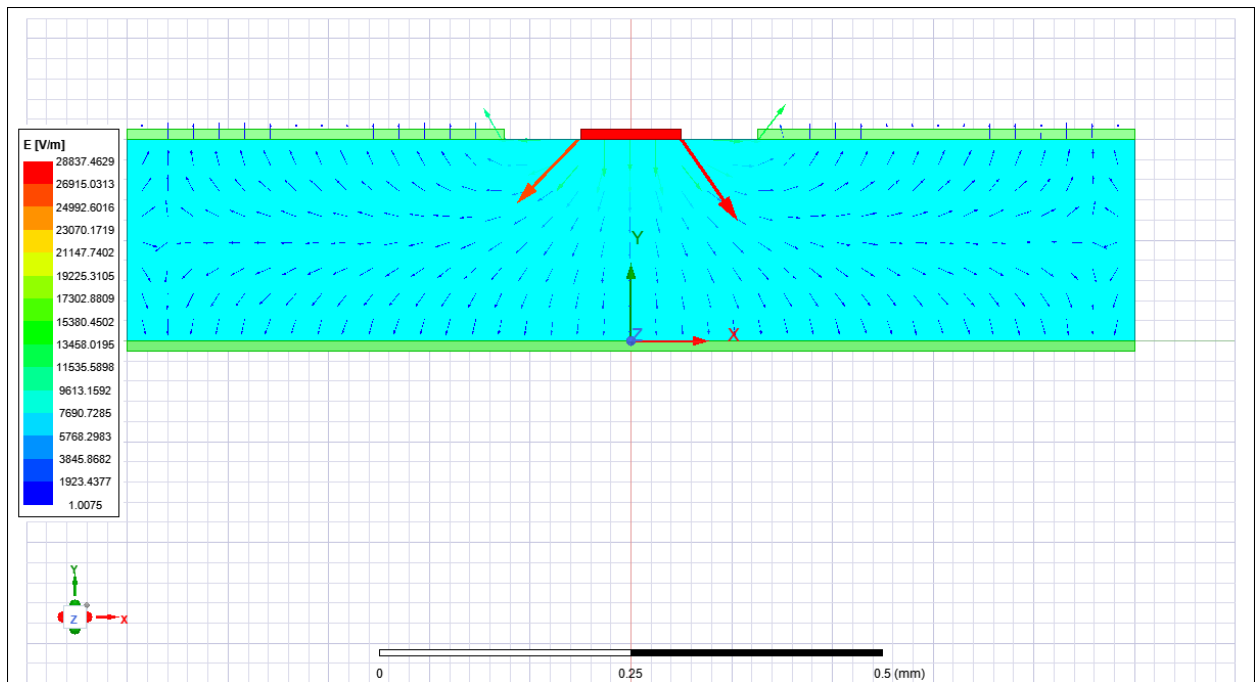

You can double-click the legend to make modifications.

For example, to modify the arrow size: select the **Marker/Arrow** tab and then drag the **Size** slider under **Arrow Options**.

JrL Field Plot

Now you will plot current density for the RL solution.

1. In the Modeling workspace, select *all of the following* objects:
 - Ground
 - top_gnd1
 - top_gnd2
 - Trace
2. Click **2D Extractor > Fields > RL Fields > J > JrL**.

The **Create Field Plot** window appears.

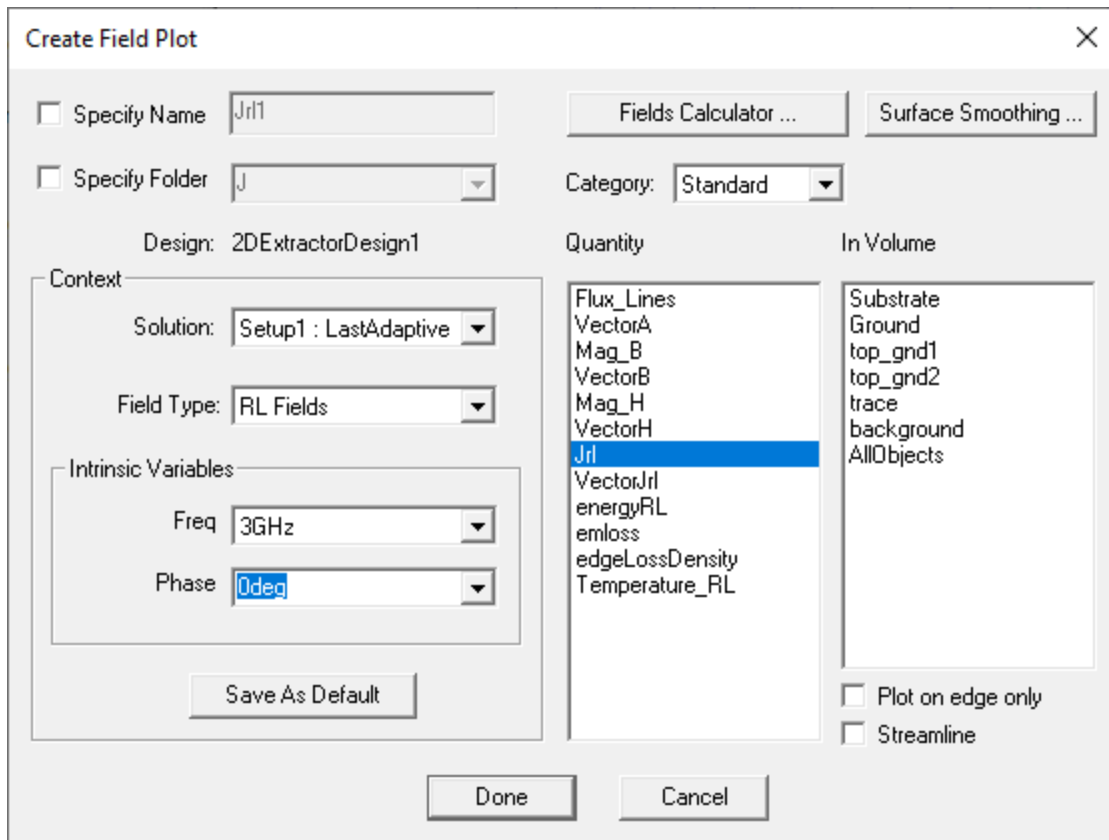

3. Leave all default values unchanged, and click **Done**.

The field plot appears, atop the previous plot.

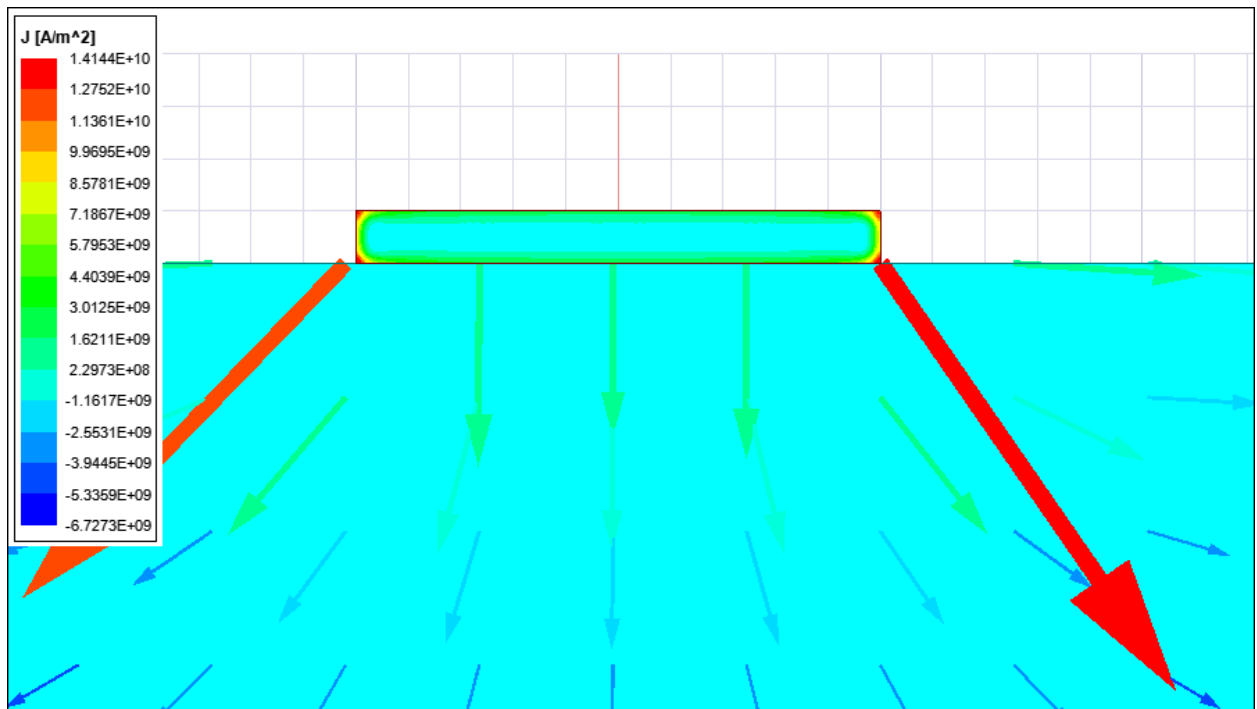

You can see that a large amount of current is returning through the coplanar grounds.

You can change the amount of current (RL) or voltage (CG) that is applied to a particular conductor, by clicking **2D Extractor > Fields > Edit Sources**.

Changing Overlay Visibility

The VectorE and JrL field plots appear in the **Project Manager** under **Field Overlays**.

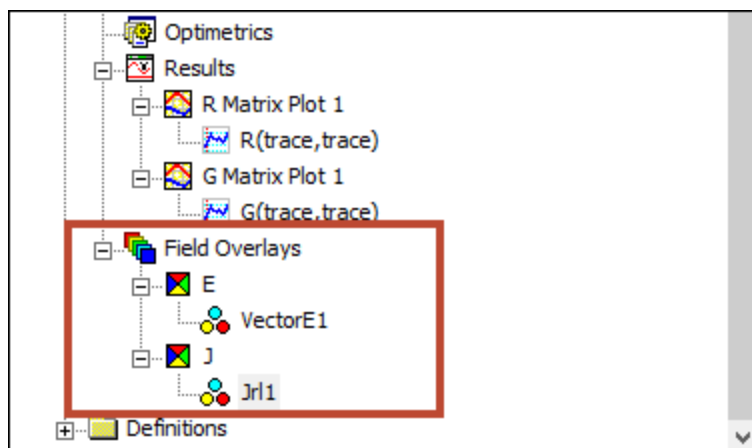

Right-click either and deselect **Plot Visibility** to hide the field plot. Re-select **Plot Visibility** to show the plot.

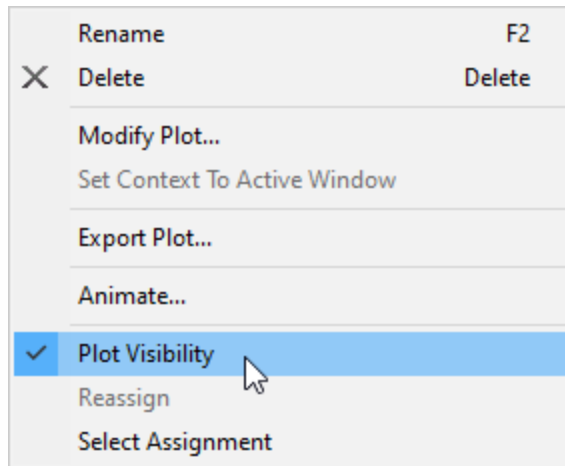

Exporting a Circuit Model

Now that you have the solution, you will export a SPICE model to simulate the effects of the trace on a signal that passes through it.

1. In the **Project Manager**, right-click **Setup1** and select **Export Circuit**.

The **Export Circuit** window appears.

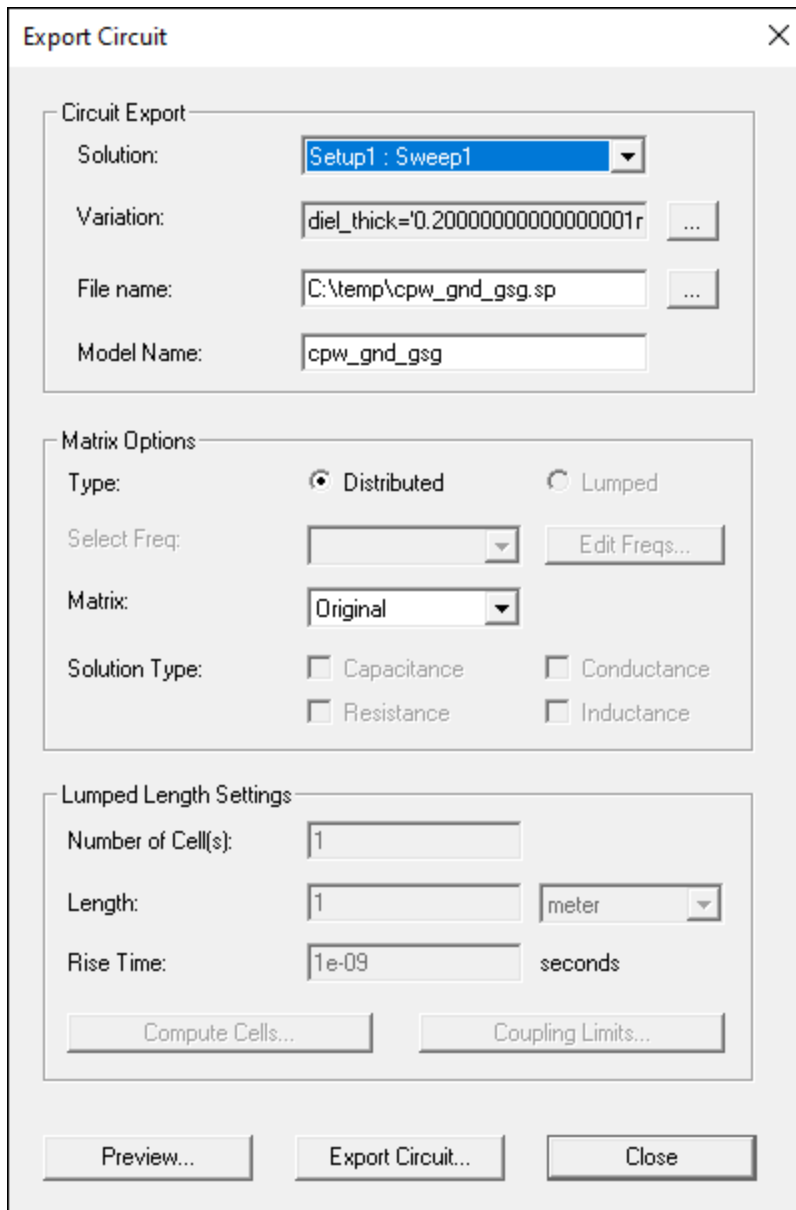

2. Use the **Solution** drop-down menu to select **Setup1:Sweep1**.
3. Specify a circuit type for export:
 - a. Click the ellipses button (...) next to **File Name**.
 - b. Use the drop-down menu to select **Nexxim/HSPICE W Element (*.sp)**.
 - c. Specify a **File Name** and select a location to save the file.
 - d. Click **Open** to return to the **Export Circuit** window.

Since we chose to export based on the sweep solution, a tabular W element table model (RLGC data at each frequency point) will be created.

4. Click **Export Circuit**.

A dialog box opens, alerting you that the file has been created.

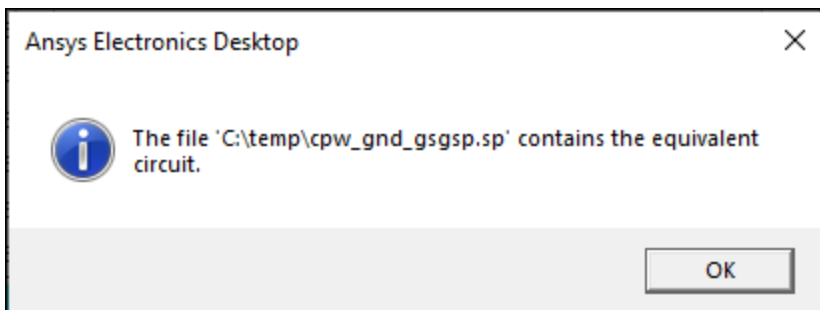

5. Click **OK** to exit the dialog box.
6. Click **Close** to exit the **Export Circuit** window.

Currently, the model has only a single variable available for the nominal value `diel_thick` (0.2mm).

Next you will set up a parametric analysis to sweep the variable over a range of values. This will allow you to export different equivalent circuit models corresponding to the different values of these variables.

Adding a Parametric Sweep

A parametric setup is made up of one or more variable sweep definitions. A variable sweep definition is a set of variable values within a range that Optimetrics drives 2D Extractor to solve when the parametric setup is analyzed. You can add one or more sweep definitions to a parametric setup.

1. Click **2D Extractor > Optimetrics Analysis > Add Parametric**.

The **Setup Sweep Analysis** window appears, on the **Sweep Definitions** tab.

2. Click **Add**.

The **Add/Edit Sweep** window appears.

3. Use the **Variable** drop-down menu to ensure that **diel_thick** is selected.
4. Use the radio buttons to ensure that **Linear Step** is selected.
5. Enter the following values:
 - **Start:** 0.2mm
 - **Stop:** 0.5mm
 - **Step:** 0.05mm
6. Click **Add**.

The sweep is added to the list on the right.

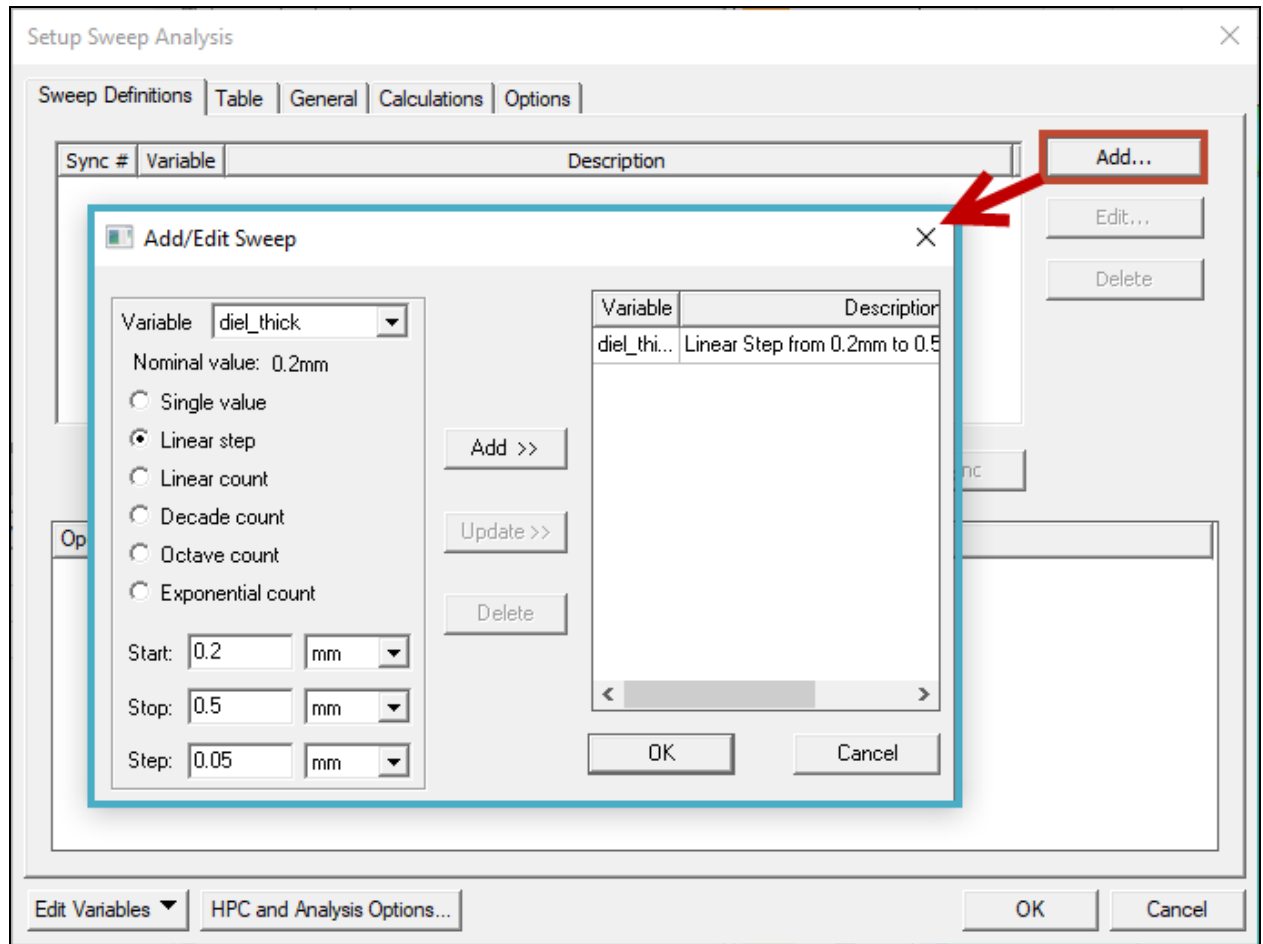

7. Click **OK** to add the sweep.
8. Click **OK** to close the **Setup Sweep Analysis** window.

The model is simulated with various values in the specified range, including the start and stop values.

The sweep is listed in the project tree under **Optimetrics** as **ParametricSetup1**.

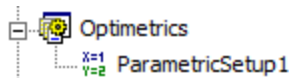

Now you will add an output calculation of the resistance matrix.

1. In the **Project Manager**, right-click **ParametricSetup1** and select **Properties**.

The **Setup Sweep Analysis** window opens again.

2. Select the **Calculations** tab.
3. Click **Setup Calculations**.

The **Add/Edit Calculations** window appears.

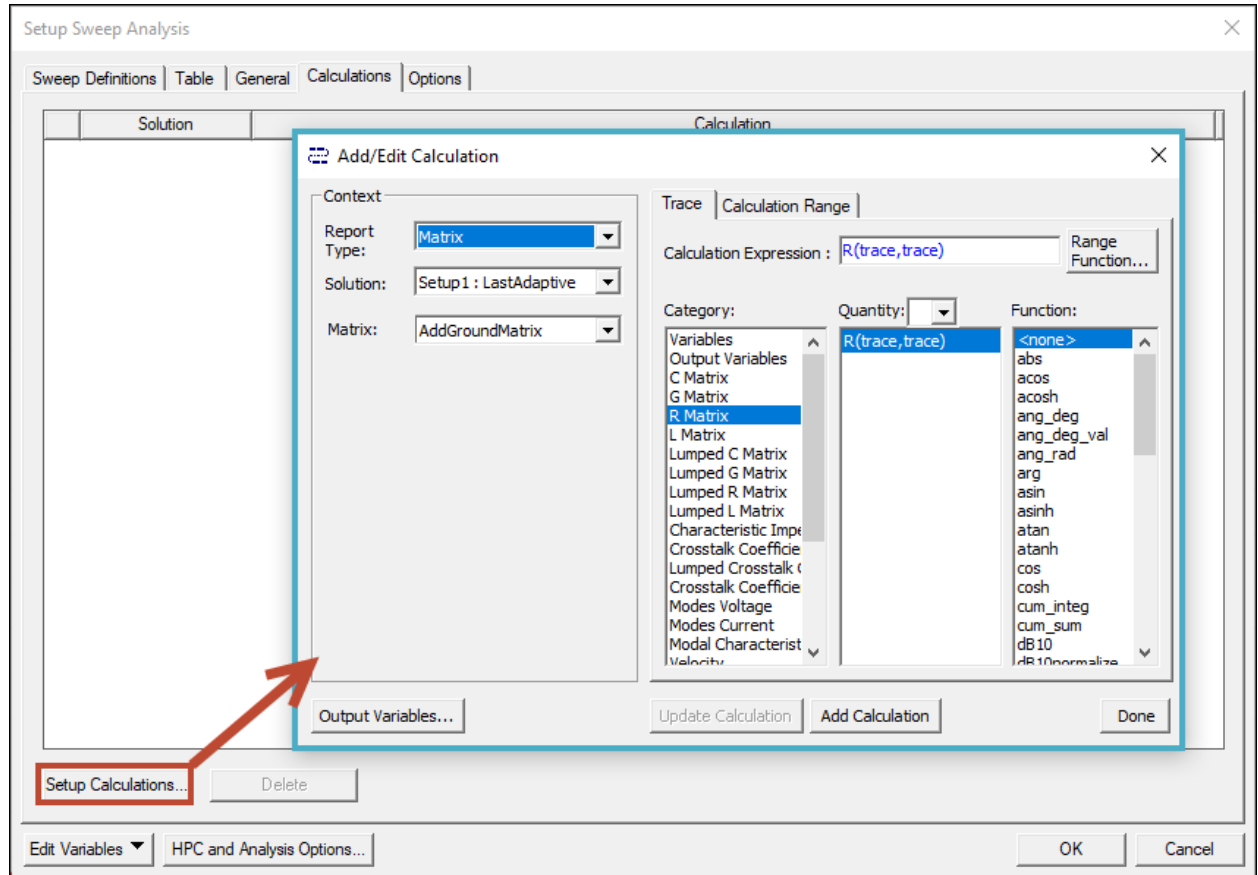

4. Use the **Report Type** drop-down menu to verify that **Matrix** is selected.
5. Use the **Solution** drop-down menu to select **Setup1:LastAdaptive**.
6. Use the **Matrix** drop-down menu to select **AddGroundMatrix**.
7. In the **Category** list, select **R Matrix**.
8. In the **Quantity** list, select **R(trace,trace)**.
9. Click **Add Calculation**.
10. Click **Done** to exit the **Add/Edit Calculation** window.
11. Click **OK** to exit the **Setup Sweep Analysis** window.

Running a Parametric Analysis

For this project, you want to see only the nominal (3GHz) resistance at each parametric variation. Therefore, you can disable the frequency sweep before beginning the parametric

solution. This will significantly decrease the parametric solution time.

From the **Project Manager**, right-click **Sweep1**, and select **Disable Sweep**.

Now you can run the parametric analysis.

1. From the **Project Manager**, right-click **ParametricSetup1** and select **Analyze**.

The **Progress** window displays a progress bar.

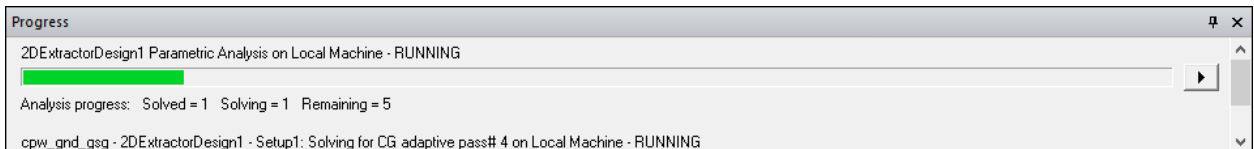

2. From the **Project Manager**, right-click **ParametricSetup1** and select **View Analysis Result**.

The **Post Analysis Display** window appears.

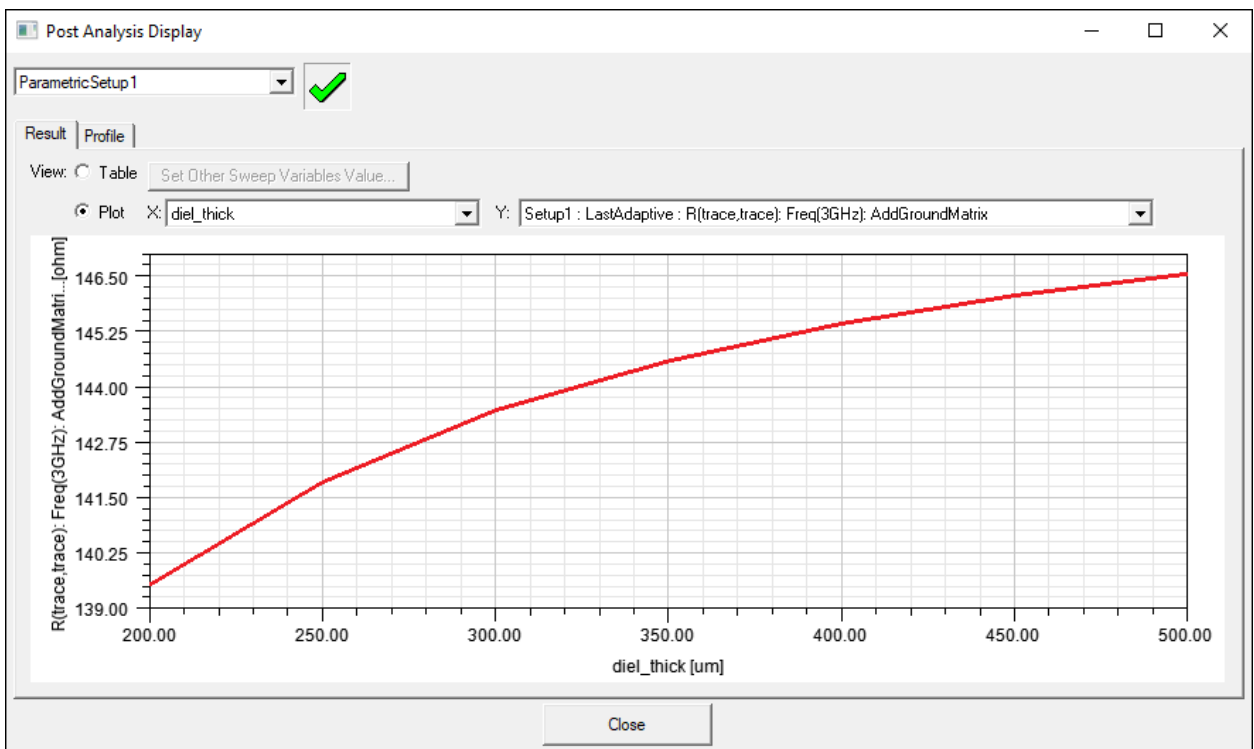

The parametric result shows how the resistance gets larger as the ground plane moves farther away from the trace. When the ground plane is farther away, more current returns in the nearby coplanar grounds (**top_gnd1** and **top_gnd2**), which have a smaller effective cross-section.

Click **Table** to view a list of the **diel_thick** values that have been solved.

3. Click the **Profile** tab to view how long it took to solve each variation.
4. Click **Close** to exit the **Post Analysis Display** window.